



10 MACHINE COMPONENTS

10.1 - List of spare parts

REFERENCE N°	DESCRIPTION
1	Base
2	Arm locking lever
3	Bush
4	
5	Roller support
6	Roller
7	Crucible
8	Electropump
9	Arm pivot
10	Bearing 51105
11	Bush
12	Hinge pivot
13	Bearing 32007 X
14	Ring Nilos 32007.XAV
15	Eccentric bush
16	Bearing 32007 XAV
17	Ring Nilos 32007 XAV
18	Ring nut Guk M 35
19	Left jaw support
20	Right jaw support
21	
22	Left countervice jaw
23	Right countervice jaw
24	Vice jaw
25	Vice
26	Vice screw
27	Spring
28	Bush
29	Léadnut
30	Spring
31	Vice gib
32	Vice support
33	Pin
34	Bush
35	Vice lever
36	Handle
37	Pin
38	Rapid locking vice lever
39	Handle
40	Bearing AX 3047 + CP
41	Bush
42	Vice handwheel
43	Bar stop rod
44	Bar stop pointer
45	Bar stop body
46	Bracket
47	Spring bush
48	Cylinder fork
49	Pin
50	Sawframe return spring

REFERENCE N°	DESCRIPTION
51	Brake cylinder
52	Cylinder articulation
53	
56	Rotation plate
57	Base
58	Right plate
59	Left plate
60	Splash protection
61	Electric box
70	Sawframe
71	
72	Blade tension plate
73	Pivot
74	Blade tension Microswitch
75	Microswitch supporting plate
76	
77	Blade tension pin
78	Springs
79	Blade tension handwheel
80	Sawframe movement lever
81	Handle with microswitch
82	Ring Nilos 32006 XAV
83	
84	Bearing 32006 X
85	Return flywheel
86	Ring nut Guk M. 30
87	Screw TE M 12
88	Washer
89	Motor flywheel
90	Bearing 6208 2RS
91	Wrench
92	Wrench
93	Motor flywheel shaft
94	Reduction unit
95	Electric motor
100	Coolant distributor
101	Connection
102	Coolant tap
103	Connection
104	Microswitch
105	Knob
106	Cover
107	Knob
108	Bracket
109	Connection



PART NUMBER	DESCRIPTION
110	Blade-guide adjustable rod
111	Short eccentric pin
112	Long eccentric pin
113	Bearing 608 2RS
114	Blade-guide protection
115	Fixed blade-guide pad
116	Mobile blade-guide pad
117	Mobile blade-guide block
118	Blade protection
119	Fixed blade-guide block
120	Blade-guide fixed rod
121	Spring support
125	Microswitch
126	Support



THOMAS

SUPER TRAD 280 MULTI MODE

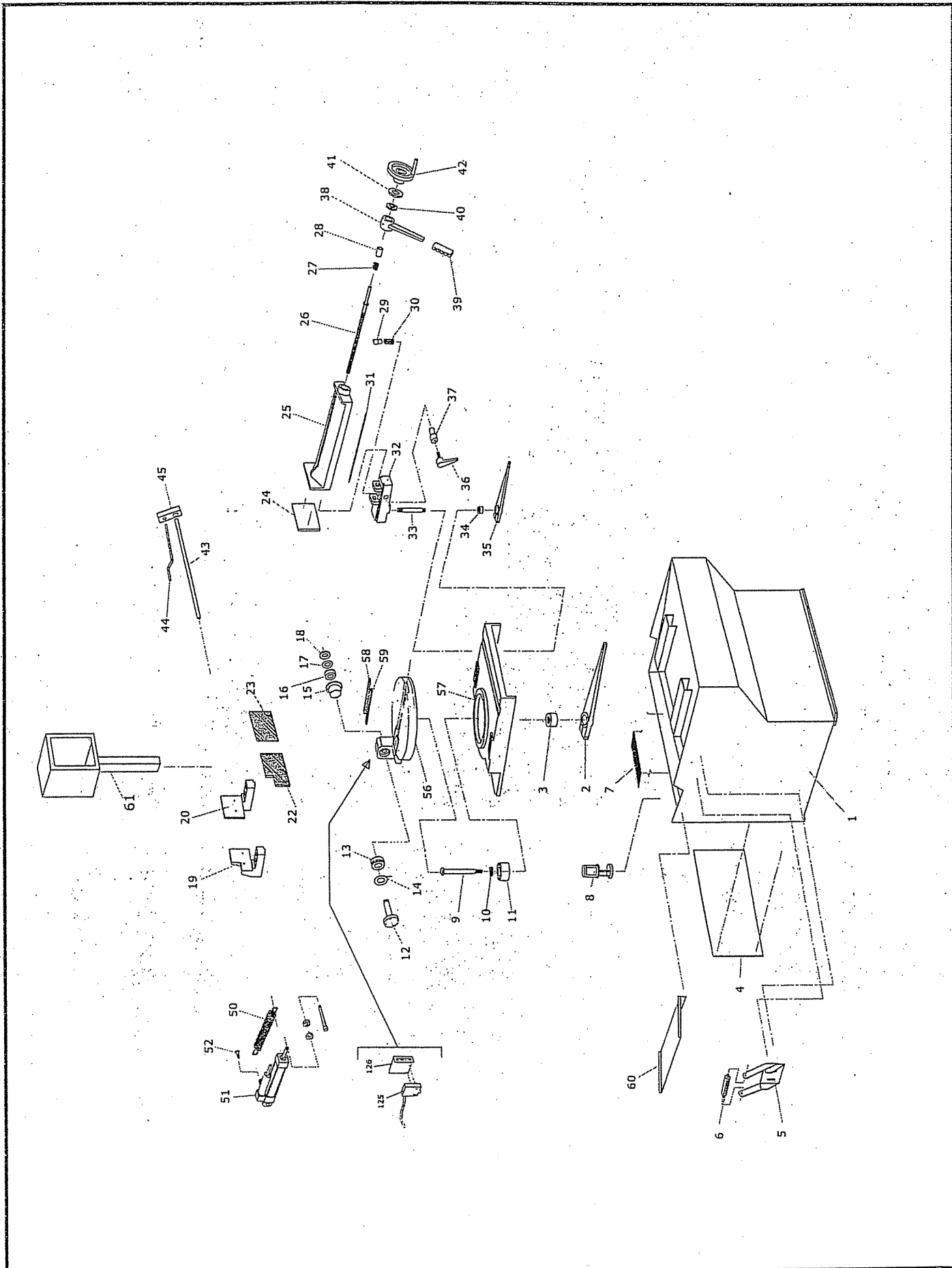

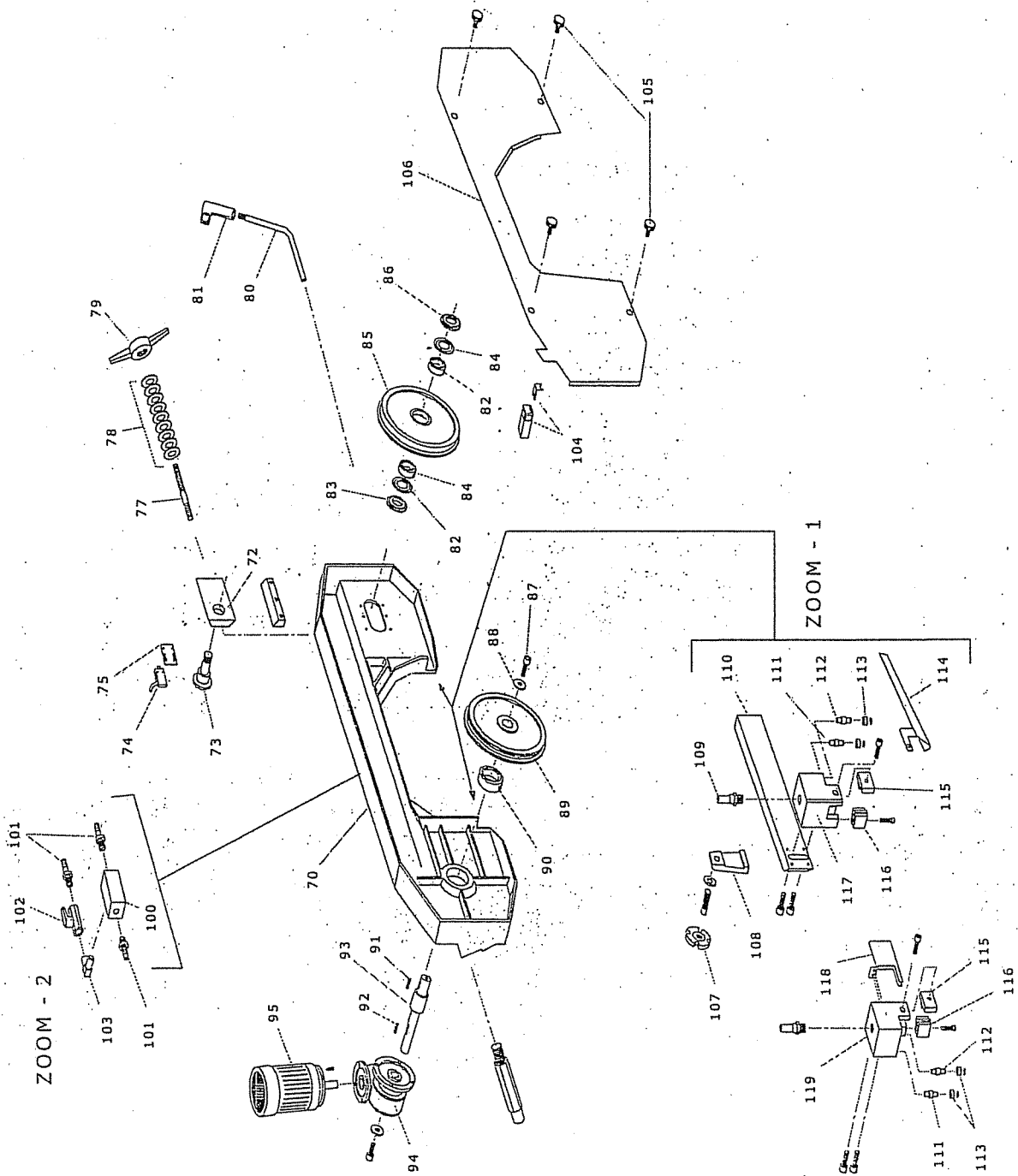



BRAKE UNIT

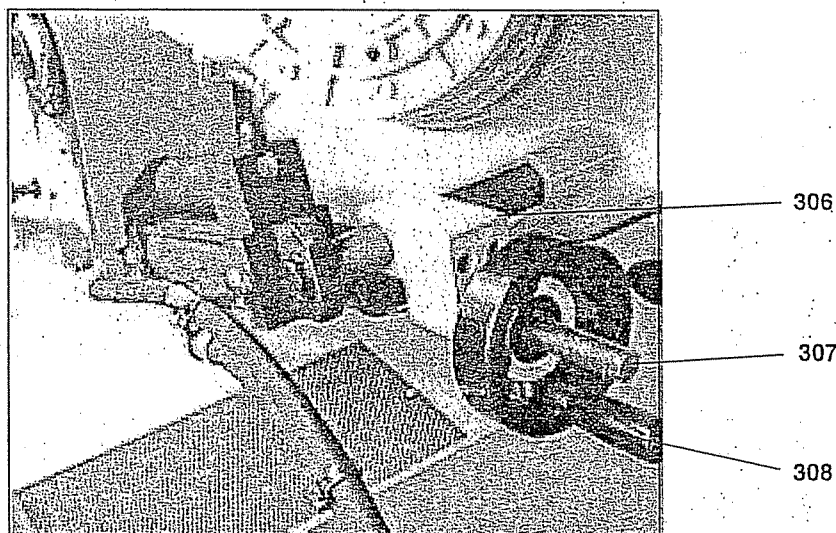
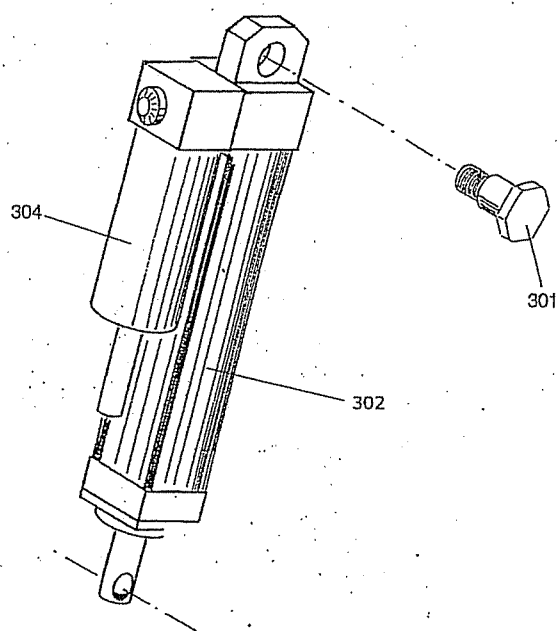

NR. RIFERIMENTO	DENOMINAZIONE
301	Cylinder articulation
302	Brake cylinder
303	
304	Tank
305	
306	Support
307	Screw
308	Handwheel

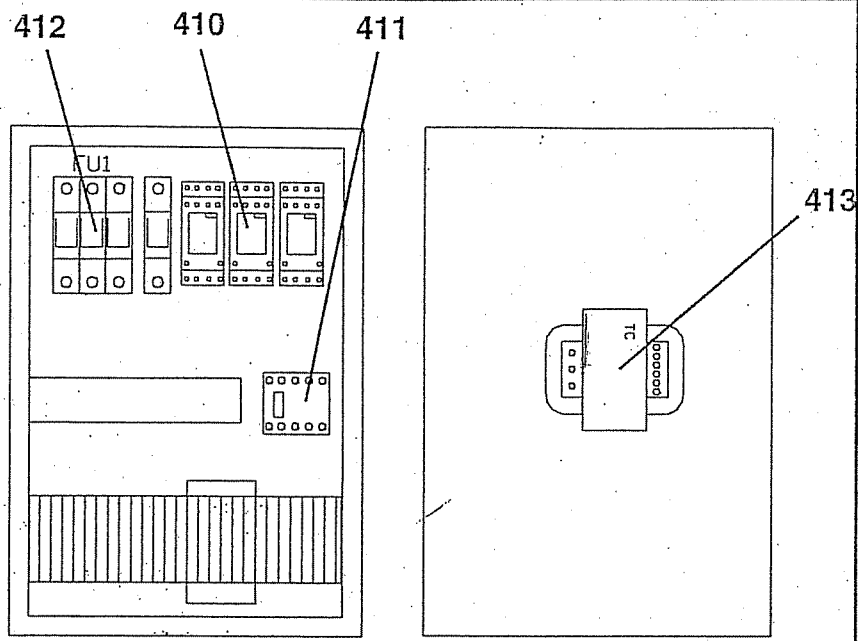

KEY

- 410 . Auxiliary relay
- 411 Remote-control switch
- 412 Fuse cartridge
- 413 Transformer

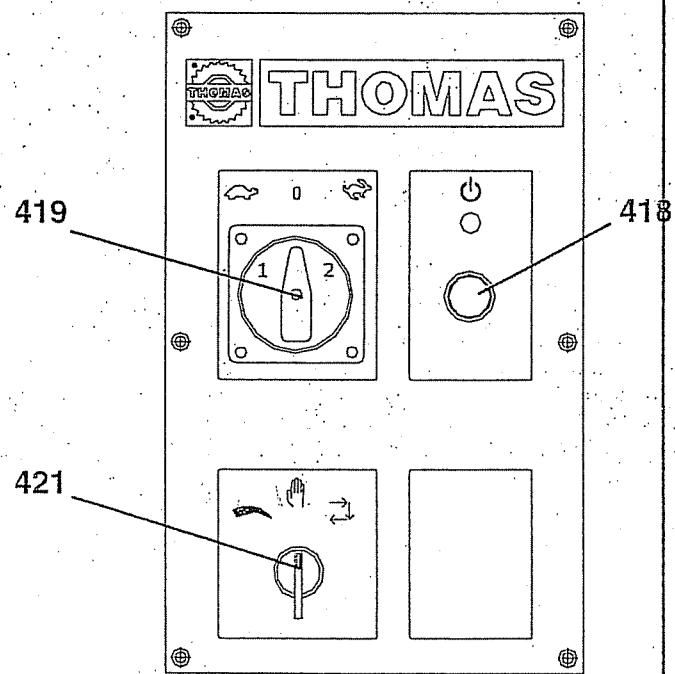
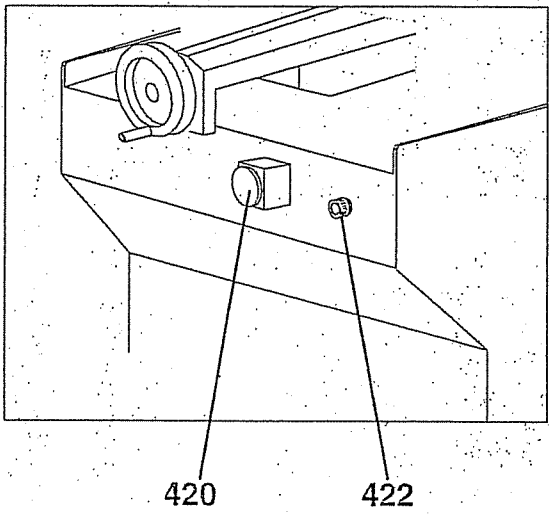

KEY

- 418 Reset push-button
- 419 Main switch
- 420 Emergency push-button
- 421 Cycle selector
- 422 Hydraulic regulator