

ONDERDEEL TEKENING

BF40GTA

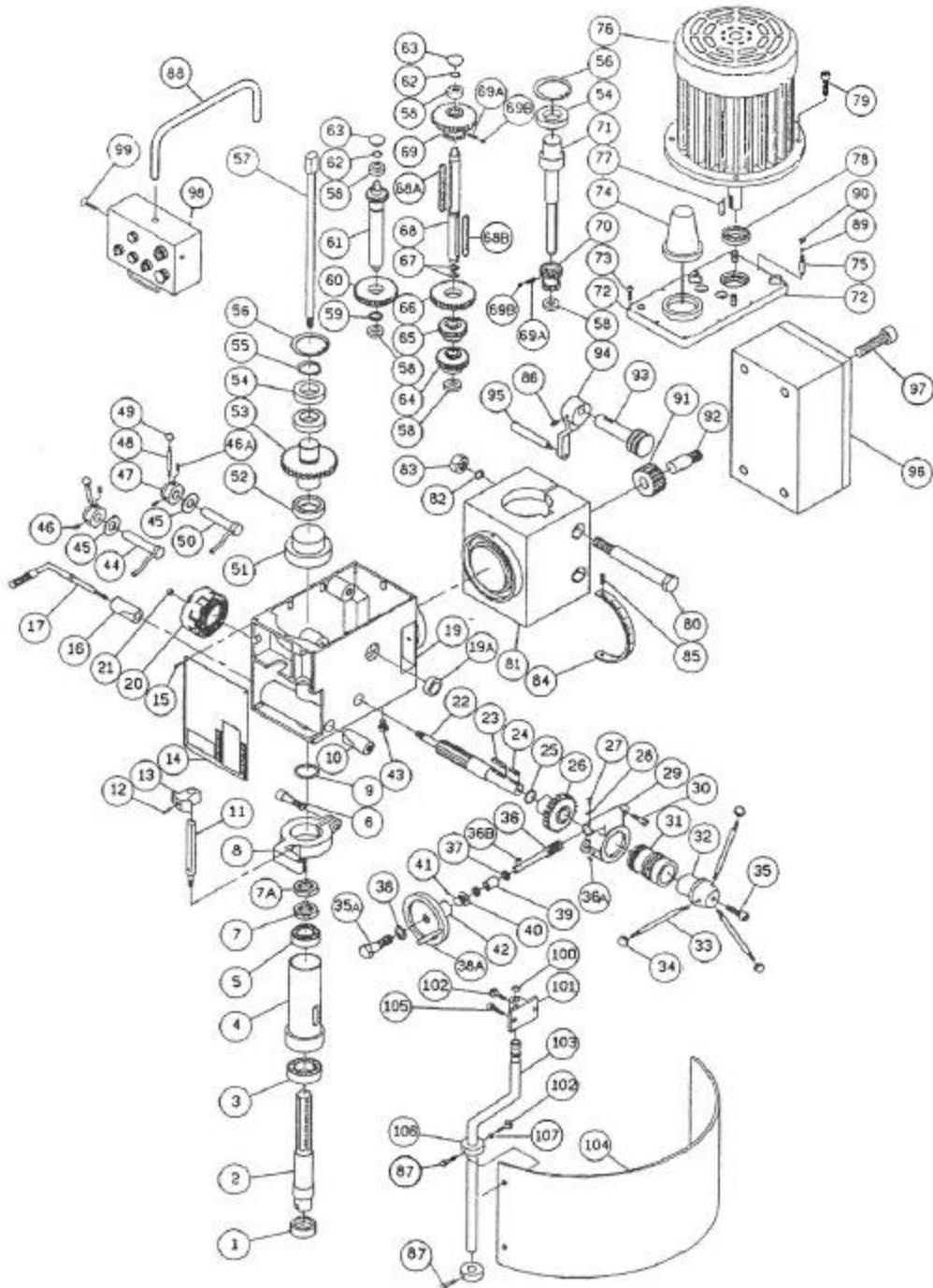

1	OIL SEAL(TCØ45xØ72x10T)	1	35A	CAP SCREW (M6x14L)	1
2	SPINDLE (MT3 OR R8)	1	36	WORM SHAFT	1
3	TAPPER ROLLOR(#30207)	1	36A	SET SCREW (M6x8L)	4
4	QUILL	1	36B	KEY (4x4x20L)	4
5	TAPPER ROLLOR (#30206)	1	37	THRUST BEARING (#51102)	2
6	CAP SCREW (M8x30L)	1	38	WASHER	1
7	GEAR WASHER	1	38A	GRIP (3/8")	1
7A	SPINLE NUT	1	39	SLEEVE	1
8	BRACKET	2	40	MICRO FEED GRADUATED DIAL(MM/INCH)	1
9	O RING 75Ø	1	41	SET SCREW (M6x8L)	1
10	HEX NUT	1	42	MICRO FEED HANDLE	1
11	STROKE ROD	1	43	OIL PLUG (3/8"~PT)	2
12	CAP SCREW(M8x16L)	1	44	GEAR CHANGE SPEED 1,2,3 ROD	1
13	FIXING BLOCK	1	45	OIL SEAL (TCØ22xØ12x7T)	2
14	NAME PLATE	1	46	SPRING SPIN (4Øx40L)	2
15	PAN SCREW	4	47	FIXING SEAT	2
16	CLAMPING PIPE	1	48	GEAR CHANGE SPEED LEVER	2
17	CLAMPING HANDLE	1	49	GRIP HANDLE(3/8")	2
18	CLAMPING NUT	1	50	GEAR CHANGE H&L ROD	1
19	GEAR BOX	1	51	SLEEVE	1
19A	OIL WINDOW(1/2" PT)	1	52	OIL SEAL (TCØ47x35x7T)	1
20	DISC SPRING SET	1	53	GEAR (M2x53T)	1
21	HEX NUT	1	54	BALL BEARING(6007Z)	2
22	PINION SHAFT	1	55	C-RING (S35)	1
23	KEY (5x5x40L)	1	56	SNAP RING(R62)	1
24	KEY (5x5x20L)	1	57	DRAW BAR (M12x1.75P)	1
25	C-RING(S26)	1	58	BALL BEARING (6202Z)	5
26	WORM GEAR	1	59	C-RING (S22)	1
27	INDICATOR	1	60	GEAR (M2x41T)	1
28	RIVET	2	61	C-SHAFT GEAR (M2x15T)	1
29	WORM GEAR COVER	1	62	SNAP-RING (R35)	2
30	CAP SCREW (M8x16L)	2	63	END COVER	2
31	MIRCO FEED CONNECTOR	1	64	GEAR ((M2x35T))	1
32	FIXING SEAT	1	65	GEAR (M2x28T)	1
33	FIXING SEAT HANDLE	3	66	GEAR (M2x44T)	1
34	GRIP HANDLE 1/2"	3	67	C-RING (S18)	2
35	CAP SCREW (3/8"x1")	1	68	B-SHAFT	1

68A	KEY (5x5x50L)	1	102	PAN SCREW(3/8")	2
68B	KEY (6x6x75L)	1	103	BRACKET ARM	1
69	GEAR (M2x16T/42T)	1	104	SAFTY GUARD	1
69A	SPRING	2	105	CAP SCREW (M8x16L)	2
69B	BALL Ø8	2	106	BRACKET BUSH	2
70	GEAR (M2x31T/15T/23T)	1	107	WASHER(3/8")	2
71	A-SHAFT	1			
72	GEAR BOX COVER	1			
73	CAP SCREW(6x25L)	8			
74	SPINDLE TOP COVER	1			
75	TAPER PIN(NO.4)	2			
76	MOTOR(AC 1.5HP/2 HP)	1			
77	KEY(6x6x30L)	1			
78	OIL SEAL(TCØ30x55x7T)	1			
79	CAP SCREW (M8x20L)	4			
80	HEX SCREW (5/8"x7"L)	2			
81	ELEVATING SWIVEL CASE	1			
82	WASHER	2			
83	HEX NUT (5/8")	2			
84	TILTING GRADUATED PLATE	1			
85	RIVET	3			
86	SET SCREW (M8x12L)	1			
87	PAN SCREW (M6x8L)	2			
88	SWIVEL BAR	2			
89	WASHER	2			
90	HEX NUT(M6)	2			
91	WORM WHEEL	1			
92	WORM WHEEL SHAFT	1			
93	WORM SHAFT	1			
94	CRANK HANDLE	1			
95	GRIP(3/8")	1			
96	SWITCH CONTROL BOX	1			
97	PAN SCREW (M5x10)	2			
98	SWITCH BOX	1			
99	PAN SCREW (M6x8L)	2			
100	C-RING(S12)	1			
101	BRACKET	1			

CENTRAL LUBRICATING OIL-FEEDING EQUIPMENT

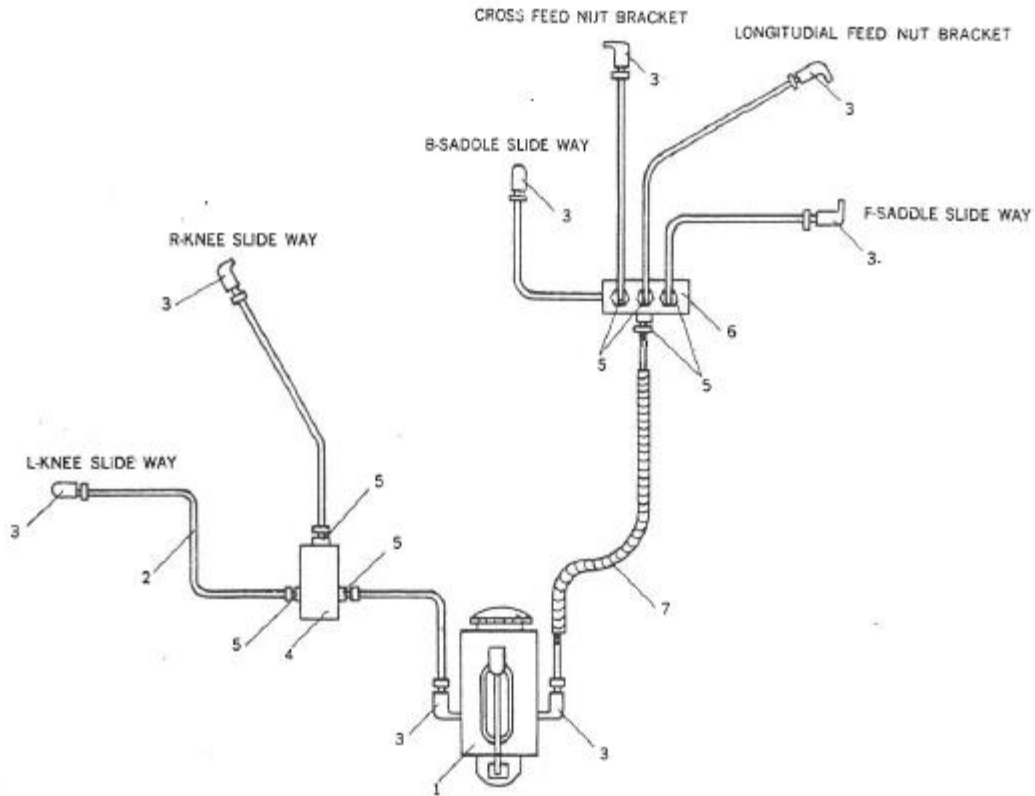

ITEM NO.	PARTS NO.	DESCRIPTION
1	9001	Hand Oiler
2	9002	Aluminum Pipe
3	9003	Elbow Joint (8 Req.)
4	9004	T-Joint
5	9005	Straight Joint (7 Req.)
6	9006	Oil Regulating Distributor
7	9007	Outside Steel Flexible Tube

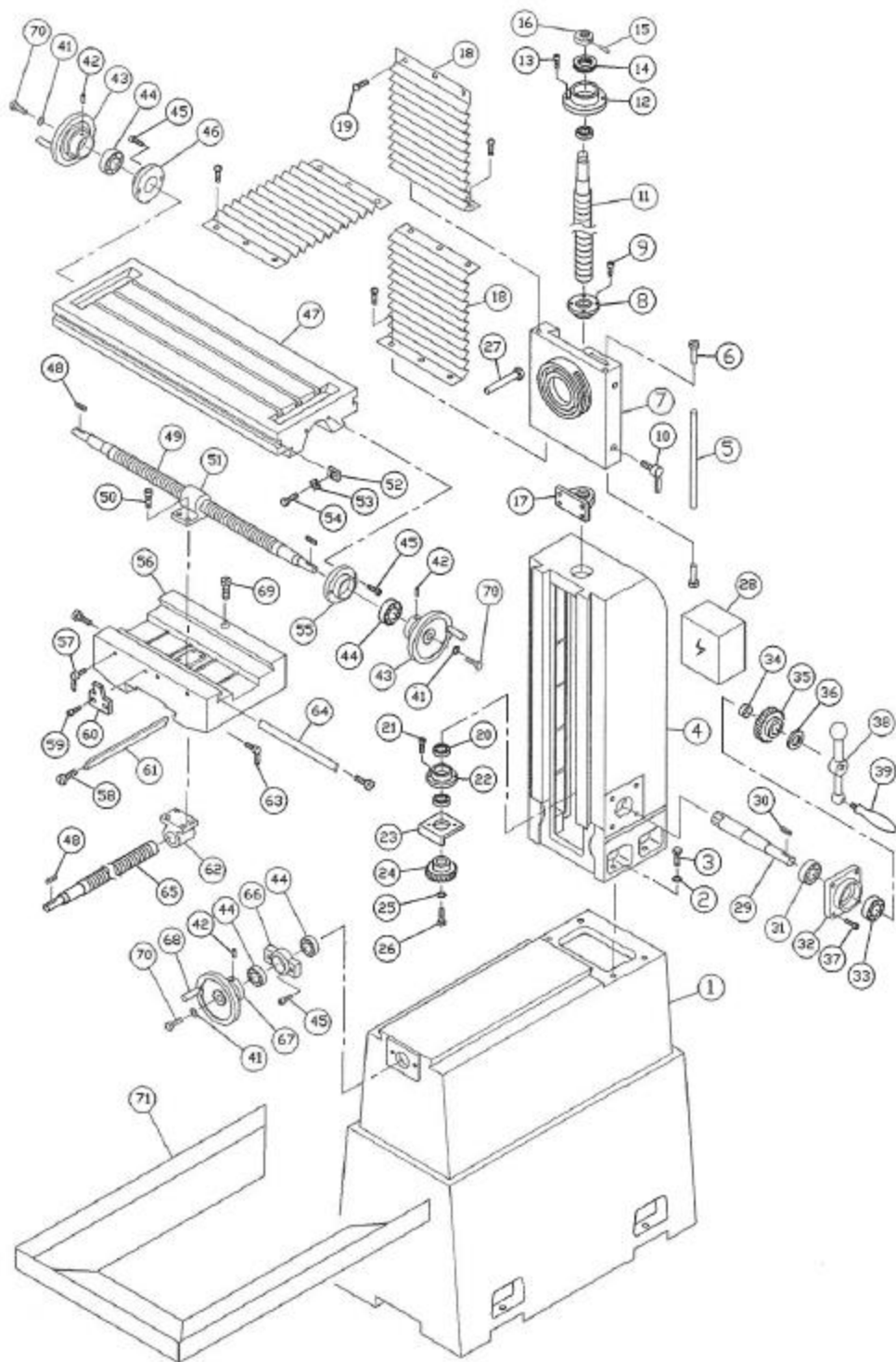

1	BASE	1	37	CAP SCREW (M8x16L)	4
2	SPRING WASHER(M16)	4	38	HANDLE	1
3	HEX BOLT(5/8"x2-1/2"L)	4	39	GRIP	1
4	MAIN COLUMN	1	40	CAP SCREW (M8x25L)	2
5	UP & DOWN TRAVEL GIB	1	40A	WASHER (M8)	4
6	GIB ADJUSTING SCREW(5/16"x24 UNF)	6	41	WASHER(M8)	3
7	UP & DOWN TRAVEL BASE	1	42	SET SCREW(M5x8L)	3
8	Z-AXIS LEAD SCREW NUT	1	43	HANDLE WREEL	3
9	CAP SCREW(M6x20L)	3	44	BALL BEARING(6002ZZ)	5
10	CLAMPING BOLT(M8)	4	45	CAP SCREW (M6x16L)	6
11	Z-AXIS LEAD SCREW	1	46	LEFT BEARING SEAT SET	1
12	SEAT SET	1	47	WORKING TABLE	1
13	CAP SCREW(M8x16L)	2	48	KEY (4x4x20L)	3
14	BALL BEARING(6002Z)	2	49	LONGIT UDINAL LEAD SCREW	1
15	SPRING PIN(4X40)	1	50	CAP SCREW (M8x20L)	2
16	SEAT RING	1	51	LONGITUDINAL LEAD SCREW NUT	1
17	SCREW NUT SET	1	52	STOPPER SET	2
18	UPPER RUBBER CHIP COVER	1	53	STOPPER BUSH	2
18A	DOWNNER RUBBER CHIP COVER	1	54	CAP SCREW (M6x20L)	2
19	CAP SCREW(M5x12L)	8	55	RIGHT BEARING SEAT SET	1
20	BALL BEARING (6003ZZ)	2	56	SADDLE	1
21	CAP SCREW (M6x20L)	2	57	SAME 10	
22	SEAT SET	1	58	SAME 6	
23	BRACKET	1	59	CAP SCREW(M8x16L)	2
24	WORM WHEEL	1	60	STOPPER BLOCK	1
25	WASHER	1	61	CROSS TRAVEL GIB	1
26	CAP SCREW (M8x14L)	1	62	CROSS LEAD SCREW NUT	1
27	T-SLOT BOLT (1 / 2"x50L)	3	63	WING SCREW (3/8")	2
28	ELETRICAL CONTROL BOX	1	64	LONGITUDINAL TRAVEL GIB	1
29	WORM SHAFT	1	65	CROSS LEAD SCREW	1
30	KEY (3x3x15L)	2	66	FRONT BEARING SEAT SET	1
31	BALL BEARING (6204ZZ)	2	67	MEMORY RING	3
32	BEARING SEAT SET	1	68	HANDLE GRIP(3/8")	3
33	SAME 31		69	CAP SCREW (M8x30L)	1
34	SEAT RING	1	70	CAP SCREW (M8x14L)	3
35	MEMORY RING	1	71	TILTING GRADUATED PLATE	1
36	SET NUT	1	72	RIVET	3
36A	MEMORY RING SET	1			