

DRILLHEAD

DCG25

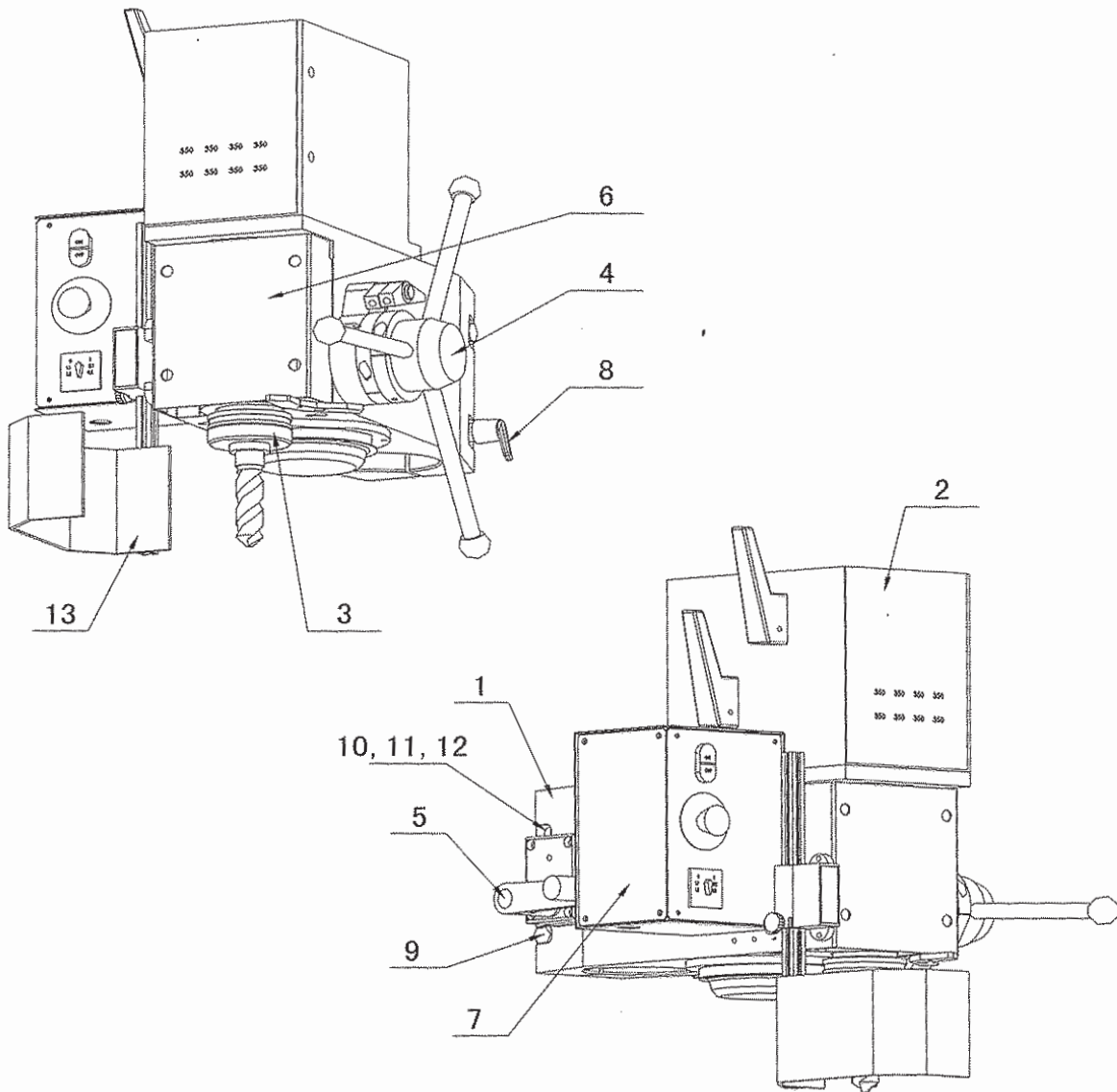

Drillhead			
pos	Art. No.	Description	Not
1.	T25-2020	Spindle housing	
2.	2X08404	Gearbox	
3.	2X08719	Spindle sleeve	
	T25A	Spindle sleeve	
4.	2X08740-5	Feedshaft compl.	
	T25A	Feedshaft compl.	
5.	2X08720	Worm unit	
6.	T25I-1002	Front cover	
	T25A-3027	Front cover	
7.	T25-4000	Electric box cover	
8.	3R00014	Locking lever	
9.	3S02556	Screw	M12X130
10.	3S02558	Screw	M12X120
11.	3M09122	Locking Nut	M12
12.	3B04178	Washer	12
13.		Protection	

GEAR BOX

DCG25

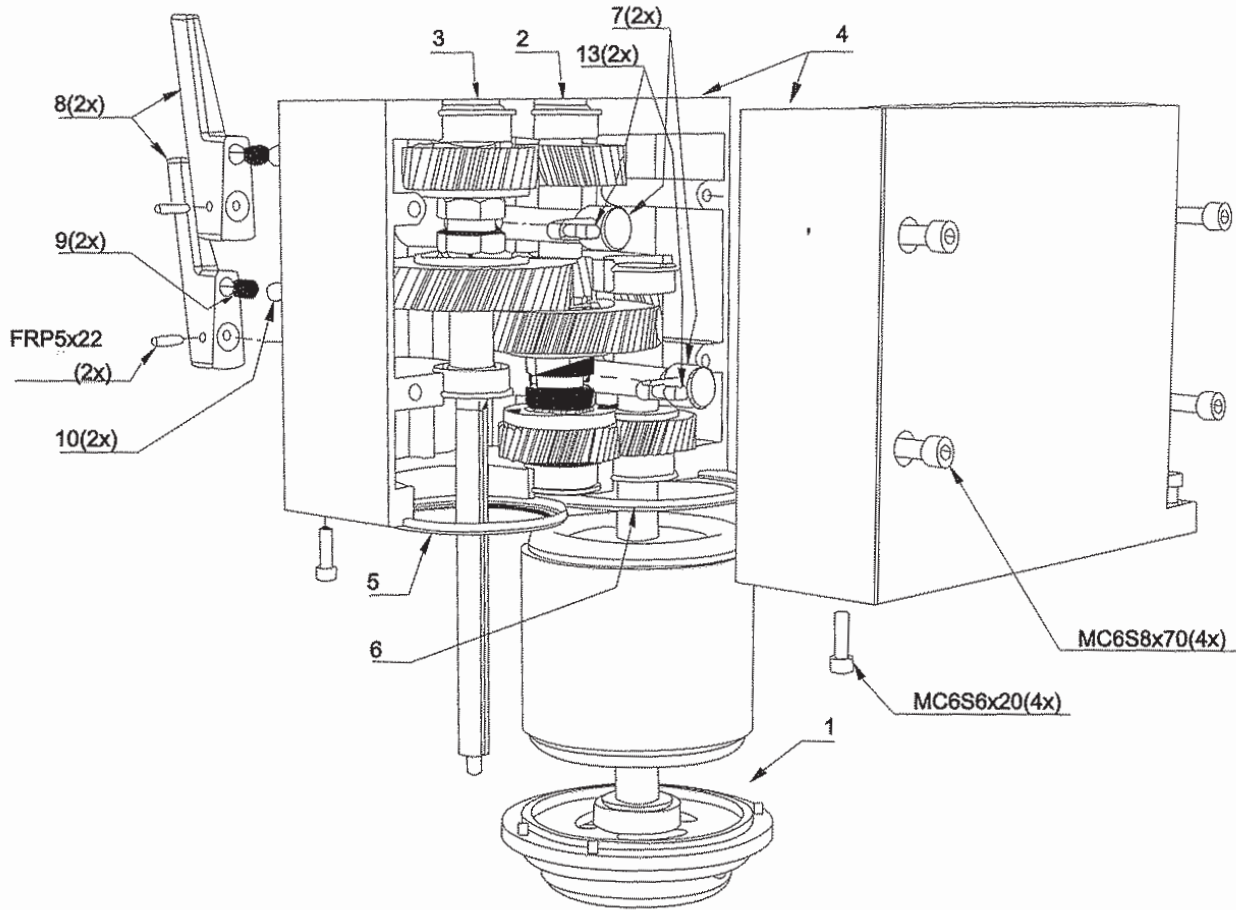

Gear box

Pos	Art. No.	Description	Not
1.		Rotor shaft	
2.	2X08404-2	2:nd Shaft complete	
3.	2X08404-3	3:rd Shaft complete	
4.	2X08422	Gear box complete	
5.	4B00174	Ring	
6.	4B00173	Ring	
7.	2X08536	Gear selector arm	
8.	4RS0653-1	Gear lever	
9.	4C02921	Gear	
10.	3T04028	Steel ball	
13.	4T04168	Shift pin	

SHAFT, ENGINE

DCG25

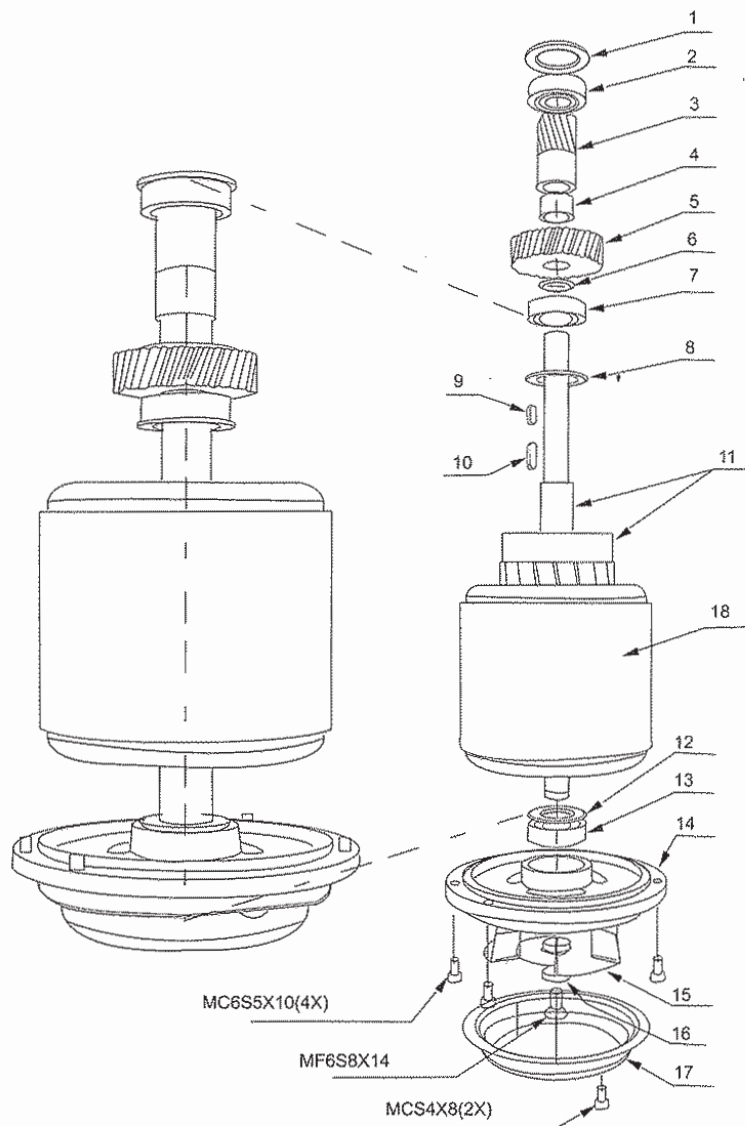

Rotorshaft			
Pos	Art. No.	Description	Not
1.	4B00137	Washer	
2.	3L11003	Ball bearing	6203
3.	2H07969	Gear	15-1,5
4.	2D17014	Spacing sleeve	17x14
5.	2H07972	Gear	39-1,5
6.	2D17002	Spacing sleeve	17x2
7.	3L11003	Ball bearing	6203
8.	4B00137	Washer	
9.	3K00184	Key	5x5x14
10.	3K00187	Key	5x5x20
11.	2X08405	Rotorshaft	
12.	4F06203	Washer	FB 6203
13.	3L11003	Ball bearing	6203
14.	2N01889	Bearing cover	B-1889
15.	4B00175	Fan	B-175
16.	2B03449	Washer	C-3449
17.	4B01890	Fan cover	C-1890
18.	3E80103	Stator 80/2-4-70	380-440

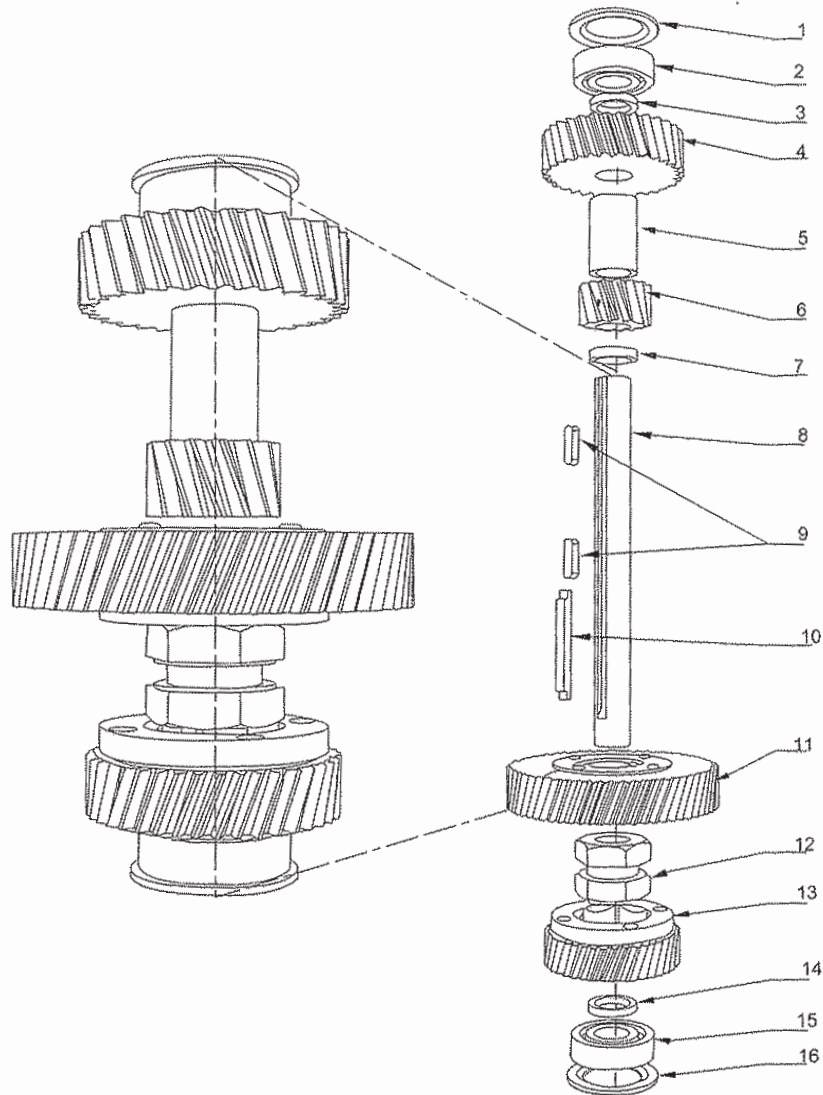

2:nd Shaft			
Pos	Art. No.	Description	Not
1.	4B00138	Washer	C-138
2.	3L11003	Ball bearing	6203
3.	2D00009	Spacing sleeve	17x3,5
4.	2H07971	Gear	32-2
5.	2D17038	Spacing sleeve	17x38
6.	2H07970	Gear	15-2
7.	2D17005	Spacing sleeve	17x5
8.	2A04871	2:nd Shaft	C-4871
9.	3K00187	Key	5x5x20
10.	2T06615	Key	C-6615
11.	2X08408	Gear complete	64-1,5
12.	2T04254	Clutch	C-4254
13.	2X08406	Gear complete	40-1,5
14.	2D00009	Spacing sleeve	17x3,5
15.	3L11003	Ball bearing	6203
16.	4B00138	Cover	C-138

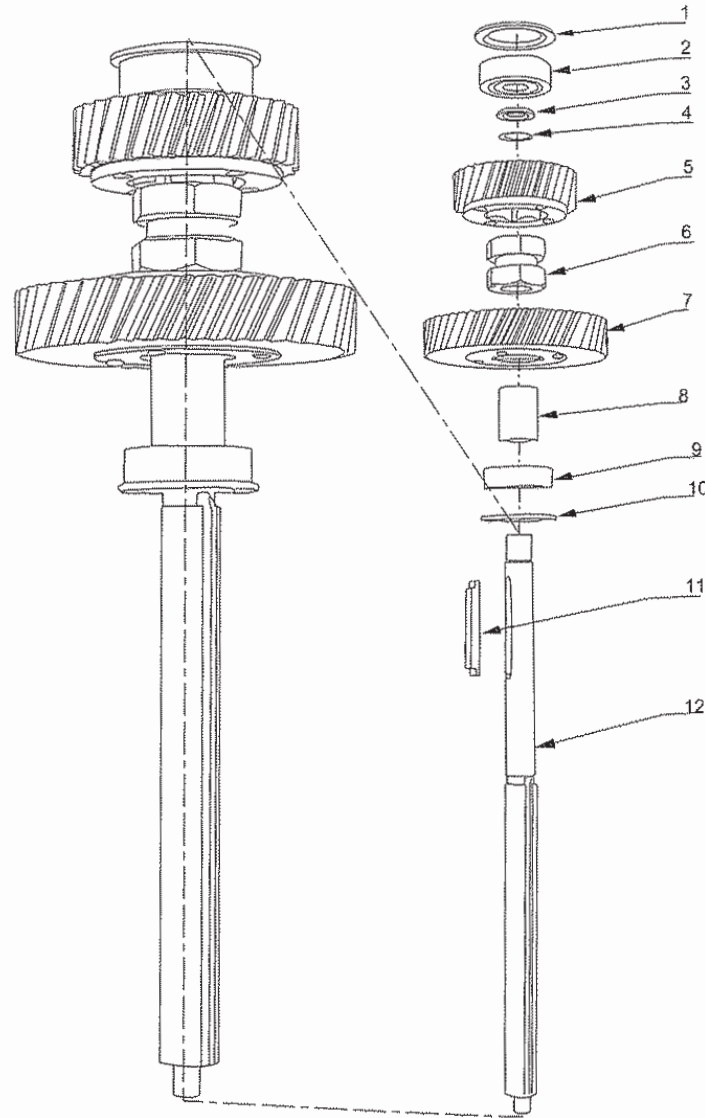

3:rd Shaft			
Pos	Art.No.	Description	Not
1.	4B00138	Cover	C-138
2.	3L16002	Ball bearing	6302
3.	3D15002	Spacing sleeve	15x2
4.	3C01117	Circlip	SgA 15
5.	2X08413	Gear complete	32-2
6.	2T04254	Clutch	C 4254
7.	2X08411	Gear complete	49-2
8.	2D00006	Spacing sleeve	17x31,5
9.	3L11003	Ball bearing	6203
10.	4B00137	Cover	C-137
11.	2T06615	Key	C-6615
12.	2A08410	3:rd Shaft	B-8410

COLUMN

DCG25

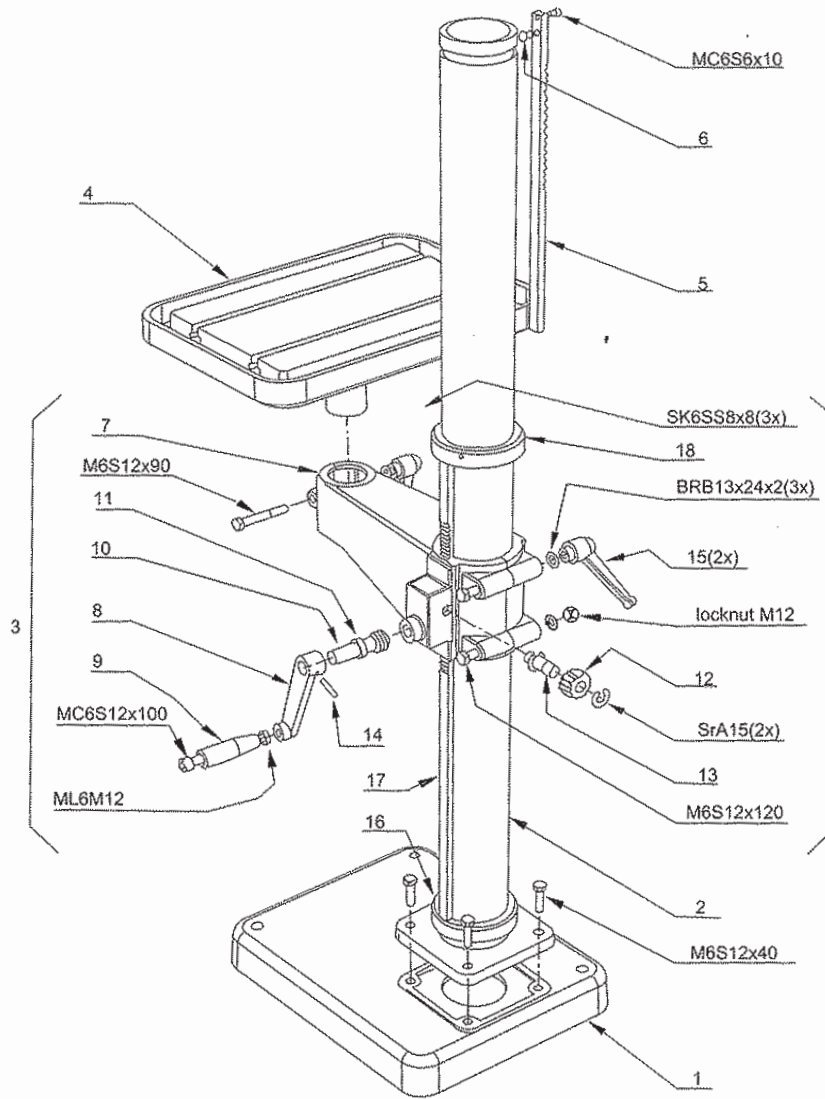

Pos	Art. No.	Column Description	Not
1.	2W07802	Base plate	
2.	4X08300	Column	L= 1500
3.	2X08723	Table arm complete	
4.	2WS1231	Table	
5.	2X08445	Rack	
6.	2T07146	Pin	
7.	2Y08723	Table arm	
	2X08720-1	Table arm gear complete	
8.	2RS1182	Crank handle	
9.	3R01106	Handle	
10.	2IS1203	Worm shaft	
11.	2D20008	Spacer	
12.	2HS1201	Gear	
13.	2AS1202	Shaft	SK6SS 8x8
14.	3S04444	Stop screw	
15.	3R00014	Locking handle	
16.	2N00186	Lower ring	
17.	2I03598	Rack	
18.	2N03668	Upper ring	

CRANK COMP.

DCG25

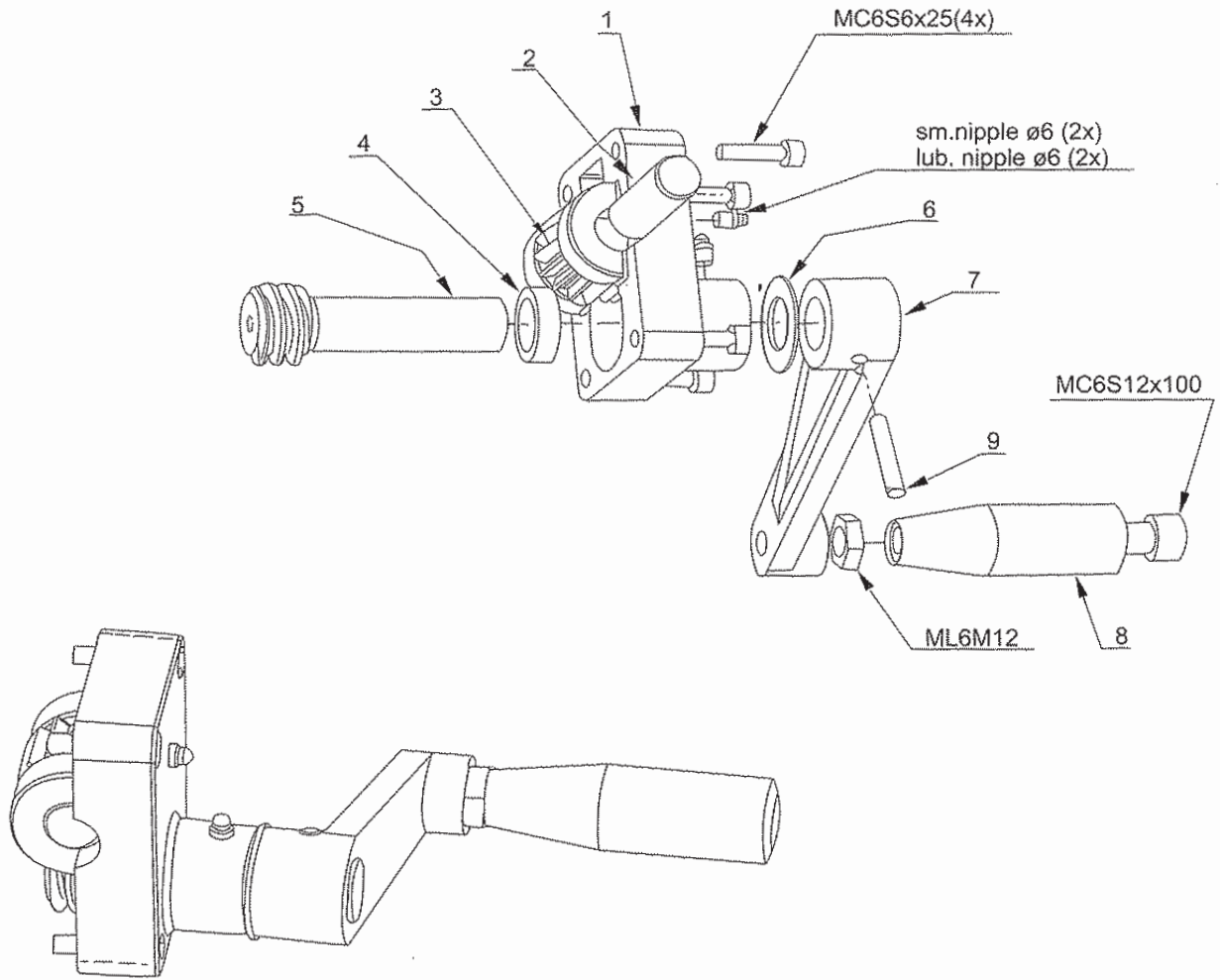

2X08720

**Worm gear box
complete**

Pos	Art. No.	Description	Not
1.	2N08720	Worm gear box	
2.	2AS1202	Shaft	
3.	2HS1201	Gear	
4.	2D20008	Spacer	20x8
5.	2IS1203	Worm shaft	
6.	3L00021	Washer	
7.	2RS1182	Crank	
8.	3R01106	Handle	
9.	3S04444	Screw	SK6SS 8x8

FEED SHAFT

DCG25

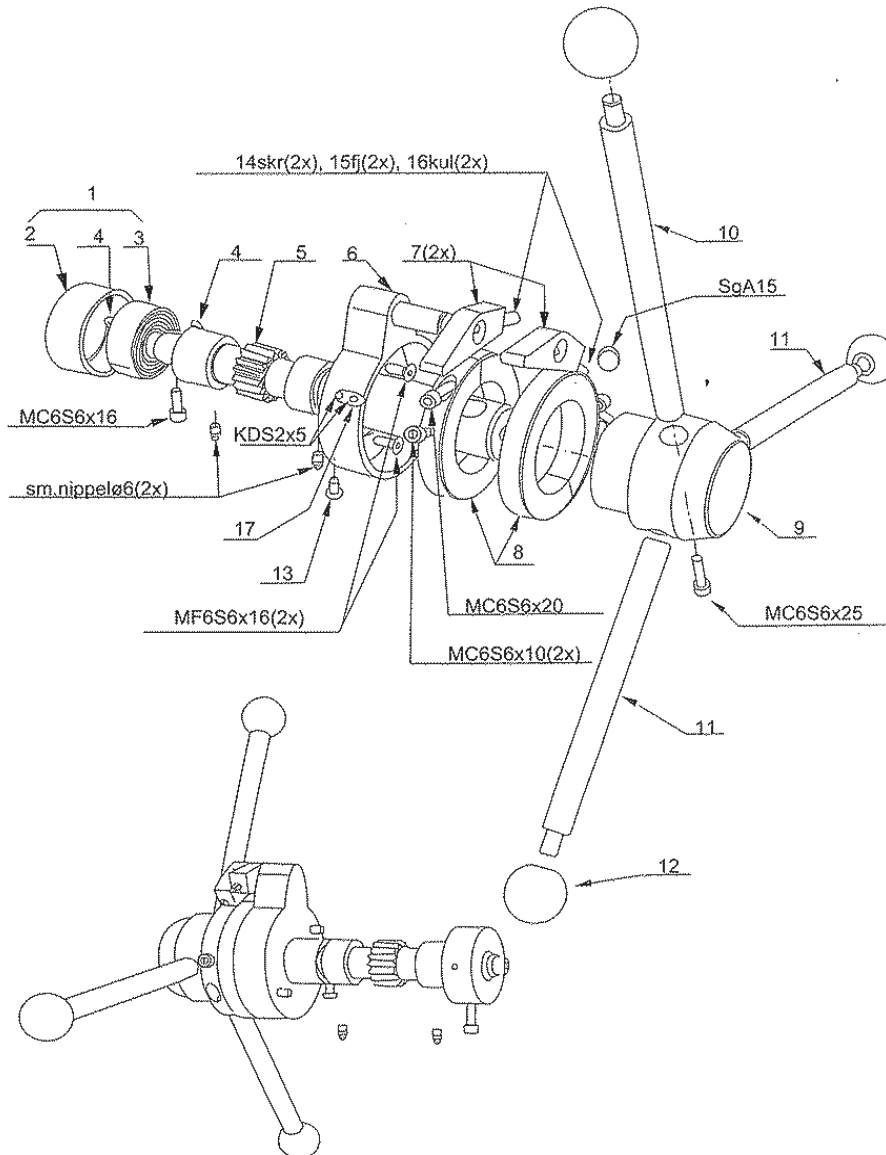

Feed shaft

Pos	Art. No.	Description	Not
1.	2X08715	Spring housing cpl	
2.	4T08715	Spring housing	
3.	4C03026	Spring	
4.	3SI1285	Screw	MFS 4x6
5.	2I08708	Feed shaft	
6.	2TS1129	Spring housing	
7.	2TS1132	Stop lug	
8.	2TS1125	Scale ring	
8a.	2TS1125-1	Scale ring	
8b.	2TS1125-2	Scale ring	
9.	2T08707	Lever hub	
10.	2E08721	Feed lever	
11.	2E08722	Feed lever	
12.	3R02003	Handle ball	
13.	4S04211	Screw	M8x8
14.	3S08443	Screw	
15.	4CS1134	Spring, stop lug	
16.	3T04022	Steel ball	
17.	4LS1124	Indicating hand	

SPINDLE SLEEVE

DCG25

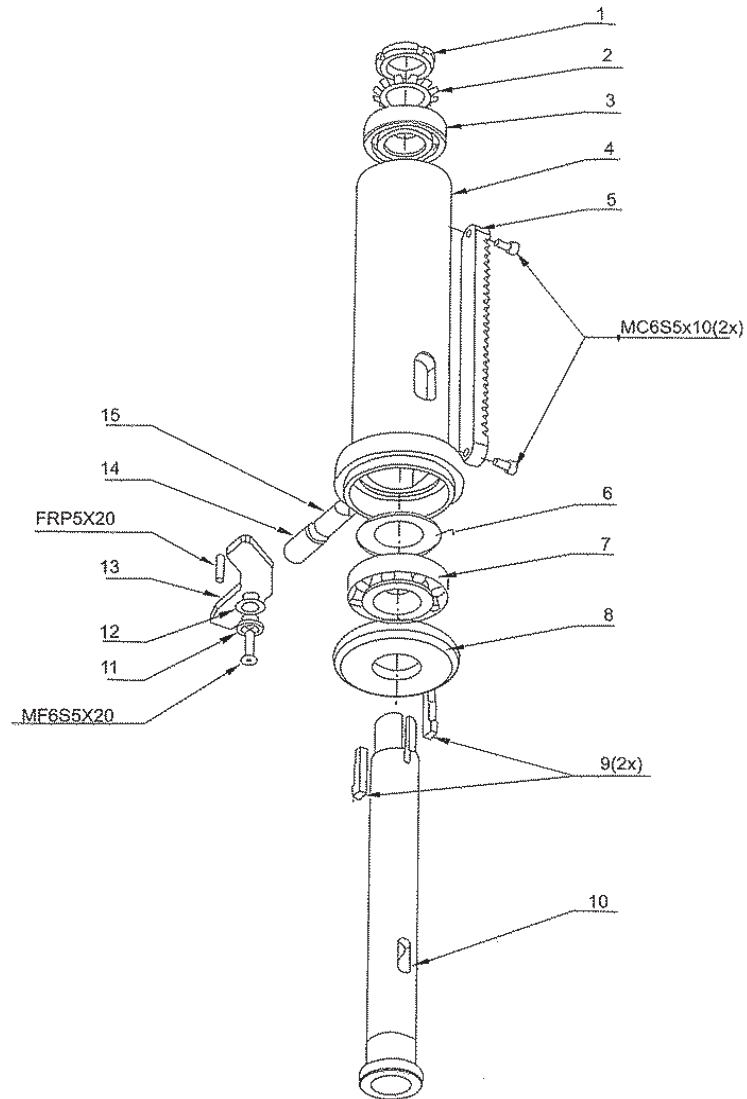

Pos	Art. No.	Spindle sleeve Description	Not
1.	3M06005	Nut	MK5
2.	4B00155	Locking washer	
3.	3L11005	Ball bearing	6205
4.	2G08709	Spindle sleeve	
5.	2I08420	Rack	
6.	4B03769	Washer	
7.	3L51006	Taper roller bearing	30206
8.	2TS1106	Roller bearing cover	
9.	2T08386	Key	
10.	2A08418-1	Spindle	
11.	2T08593	Spacing sleeve	
12.	3B06003	Washer	
13.	4T08547	Stop	
14.	3S08622	Screw	p6ss 16x 25
15.	4T08714	Collet jaw	

ELECTRIC BOX

DCG25

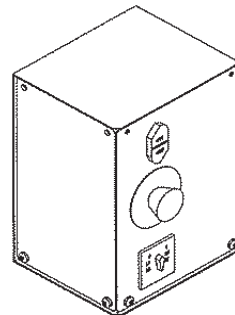
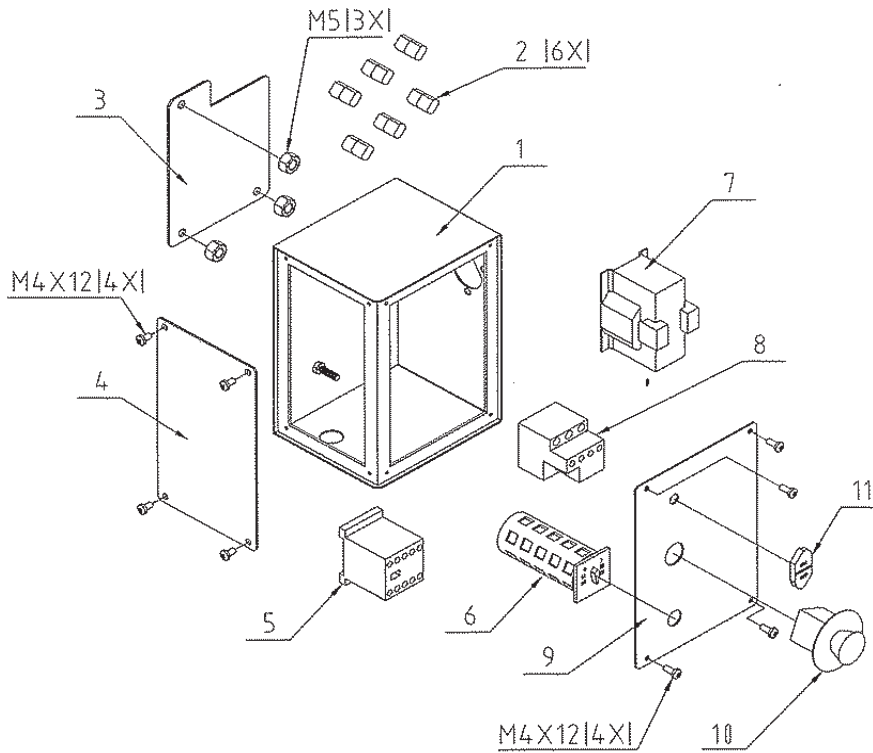

Pos	2X08705 Art.Nr.	Electric Box Description	Not
1.	T25I-4001	Electric box cover	
2.		Fuse Wire	
3.	T25I-4004	Motor Protector	
4.	T25-4002	Side Cover	
5.		A.C. Contactor	
6.		Change-over Switch (Three types)	
7.		Transformer	
8.		Thermorelay	
9.	T25-4003	Plate	
10.		Emergency Stop Switch	
11.		ON/OFF SWITCH	

OUTLINE

DCG25

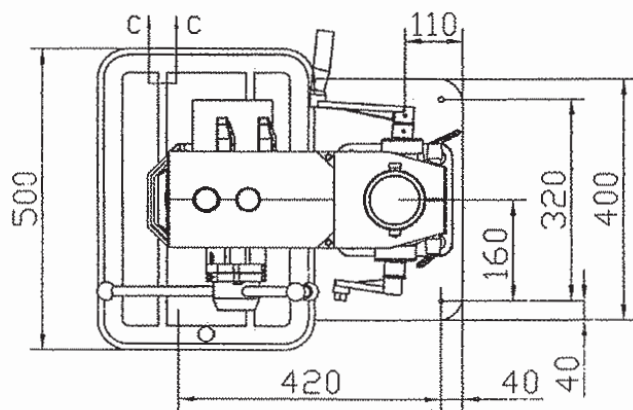
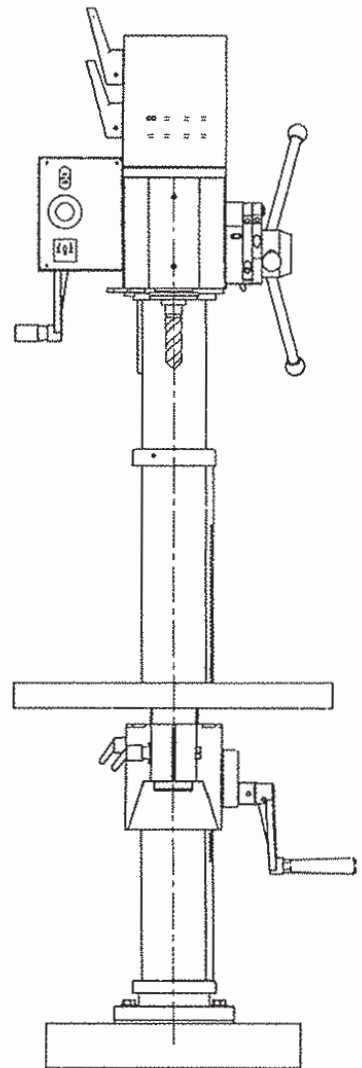
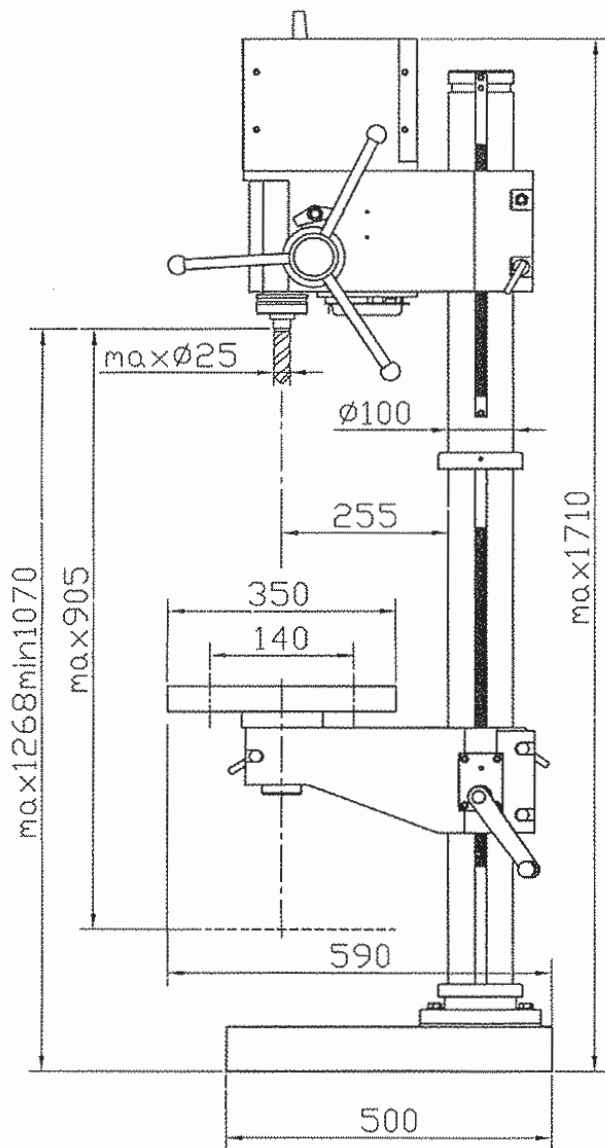

škala 0.1

Vy C-C'
škala 0.5

