

NO.	Description	Size	Q'TY
B-01	Hex Hand Plugs	3/8"	1
B-02	Sight Glass		1
B-03	Ball Bearing	6202ZZ	1
B-04	C-Clip	S-31	1
B-05	Gear	M=2,T=32	1
B-06	Key	6x20	1
B-07	Drive Shaft	M=2,T=13	1
B-08	Ball Bearing	6007Z	1
B-09	C-Clip	R-62	1
B-10	Set Screw	M10x10	2
B-11	Spring		2
B-12	Steel Ball	M8	2
B-13	Key	7x55	1
B-14	Shaft		1
B-15	Ball Bearing	6002Z	1
B-16	Gear	M=2,T=56	1
B-17	Key	6x20	1
B-18	Gear	M=2,T=36	1
B-19	Key	7x40	1
B-20	C-Clip	S-25	2
B-21	Ball Bearing	6005ZZ	1
B-22	Rod		1
B-23	Oil Ring	P-11	1
B-24	Hex Nut	M10	1
B-25	Lock Washer	M10	1
B-26	Speed Change Block		1
B-27	Screw Bar		1
B-28	Set Screw	3/8"x3/8"	1
B-29	Handle		1
B-30	Speed Lever		1
B-31	C-Clip	R-30	1
B-32	Oil Ring	30x17x7	1
B-33	Gear Shaft		1
B-34	Set Screw	M6x8	1
B-35	Hex Socket Cap Screw	M8x35	4
B-36	Oil Seal	25x5	1
B-37	Taper Pin	5x38	2
B-38	Gear Box		1
B-39	Oil Fiter	3/8"x3/8"	1

NO.	Description	Size	Q'T
B-40	Tube		1
B-41	Oil Seal	62x35x10	1
B-42	C-Clip	R-47	1
B-43	Oil Seal	47x25x8	1
B-44	Drive Pulley		1
B-45	Set Screw	M8x8	2
B-46	Drive Belt		1
B-47	Hex Socket Cap Screw	M6x16	4
B-48	Washer	M6	4
B-49	Bracket		1
B-50	Shaft		1
B-51	Ball Hushing		1
B-52	Ball Bearing	608	2
B-53	Spring Washer	M8	1
B-54	Hex Nut	M8	1
B-55	Rear Pulley		1
B-56	Set Screw	M8x8	2
B-57	Follow Belt	M5x1100x14	1
B-58	Hex Socket Cap Screw	M5x12	2
B-59	Washer	M5	2
B-60	Ball Bracket		1
B-61	Key	6x20	1
B-62	Ball Bearing	6202ZZ	1
B-63	Bearing Support		1
B-64	Flat Head Screw	5x12	2
B-65	Motor		1
B-66	Hex Socket Cap Screw	M8x25	4
B-67	Spring Washer	M8	4
B-68	Sensor		1
B-69	Sensor Support		1
B-70	Sensor Bracket		1
B-71	Screw	M4x20	2
B-72	Screw	M4x6	1
B-73	Hex Socket Cap Screw	M5x10	2
B-74	Hex Socket Cap Screw	3/16"x3/4"	1
B-75	Hex Nut	3/16"	1
B-76	Cover		1
B-77	Screw	M5x6	2

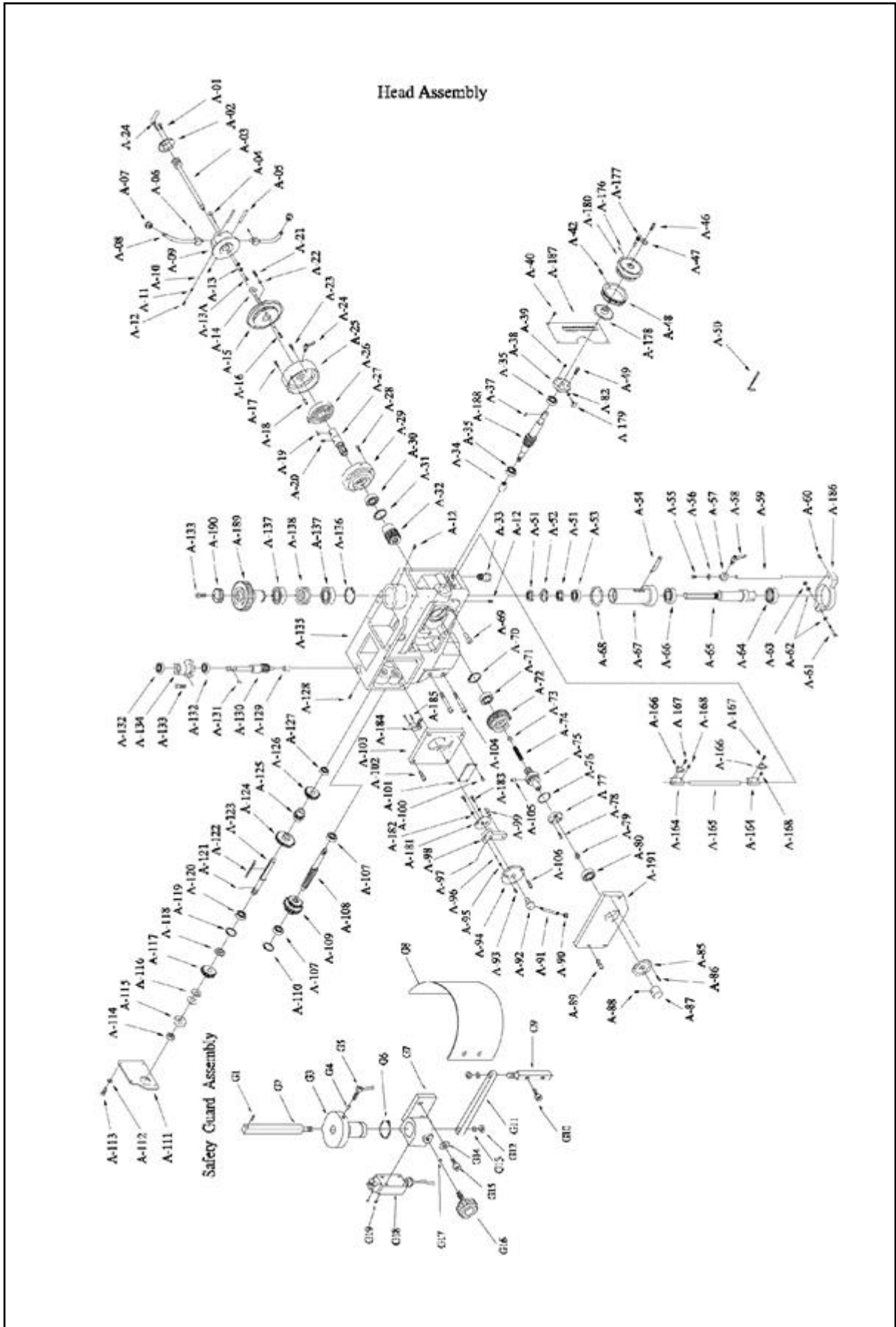

NO.	Description	Size	Q'ty	NO.	Description	Size	Q'ty
A01	Flat Head Screw	M6x16	4	A-49	Hex Socket Cap Screw	M6x16	3
A-02	Cover		1	A-50	Allen Wrench		1
A-03	Feed Clutch Rod		1	A-51	Lock Nut		2
A-04	Pin		1	A-52	Star Washer		1
A-05	Roll Pin		2	A-53	Taper Roller Bearing	30206	1
A-06	Set Screw	M5x6	2	A-54	Drill Shifter		1
A-07	Grip		2	A-55	Hex Socket Cap Screw	M6x16	1
A-08	Feed Handle		2	A-56	Washer	M6	1
A-09	Feed Handle Body		1	A-57	Depth Scale Bracket		1
A-10	Steel Ball	1/4"	1	A-58	Swivel Handle		1
A-11	Spring		1	A-59	Depth Rod		1
A-12	Set Screw	M8x8	4	A-60	Set Screw	M6x8	1
A-13	Spring Washer	M4	2	A-61	Hex Socket Cap Screw	1/4"x2"	1
A-13A	Hex Socket Cap Screw	M4x8	1	A-62	Spring Washer	1/4"	2
A-14	Scale Guider		1	A-63	Hex Nut	1/4"	1
A-15	Scale Plate		1	A-64	Oil Seal	72x45x8	1
A-16	Hex Socket Cap Screw	M4x12	2	A-65	Spindle		1
A-17	Hex Socket Cap Screw	M6x25	3	A-66	Taper Roller Bearing	30207	1
A-18	Pin		1	A-67	Quill		1
A-19	Key	6x20	1	A-68	Rubber Washer		1
A-20	Flat Head Screw	M4x8	1	A-69	Quill Support Pin		1
A-21	Hex Socket Cap Screw	M5x10	1	A-70	C-Clip	S-30	1
A-22	Hex Nut	M5	1	A-71	Ball Bearing	6206ZZ	1
A-23	Hex Socket Cap Screw	M4x5	1	A-72	Worm		1
A-24	Swivel Handle		1	A-73	Guide Plate		1
A-25	Spring Cap		1	A-74	Spring		1
A-26	Spring		1	A-75	Jaw Clutch		1
A-27	Support Shaft		1	A-76	Special Spring		1
A-28	Hex Socket Cap Screw	M6x30	3	A-77	Jaw Clutch Cover		1
A-29	Ball Support		1	A-78	Flat Head Screw	M6x16	3
A-30	Ball Bearing	6006ZZ	1	A-79	Adjustable Screw		1
A-31	C-Clip	S-30	1	A-80	Ball Bearing	6305ZZ	1
A-32	Feed Shaft		1	A-81	Feed Cover		1
A-33	Screw Bushing		1	A-82	Hex. Nut	M5	1
A-34	Sleeve		1	A-85	Cover		1
A-35	Ball Bearing	6004ZZ	2	A-86	Set Screw	M5x12	3
A-37	Key	5x15	1	A-87	Cap		1
A-38	Worm Shaft Support		1	A-88	Set Screw	M6x8	1
A-39	Set Screw	M6x12	3	A-89	Hex Socket Cap Screw	M8x20	3
A-40	Screw	M5x6	4	A-90	Grip		1
A-42	Set Knob		1	A-91	Speed Change Lever		1
A-46	Hex Socket Cap Screw	M6x16	1	A-92	Change Lever Body		1
A-47	Special Washer		1	A-93	Set Screw	M8x8	1
A-48	Scale Ring		1	A-94	Speed Change Bracket		1

NO.	Description	Size	Q'ty
A-95	Spring	M6x8	1
A-96	Steel Ball	M8	1
A-97	Spring Pin		1
A-98	Speed Change Support		1
A-99	Speed Change Pin		1
A-100	Screw	M4x6	4
A-101	Operating Lever Plate		1
A-102	Hex Socket Cap Screw	M8x25	4
A-103	Speed Change Cover		1
A-104	Hex Head Bolt	M12x80	2
A-105	Jaw		3
A-106	Hex Socket Cap Screw	M6x16	3
A-107	Ball Bearing	6003ZZ	2
A-108	Sliding Shaft		1
A-109	Speed Change Gear		1
A-110	C-Clip	R-35	1
A-111	Cover Plate		1
A-112	Spring Washer	M6	4
A-113	Hex Socket Cap Screw	M6x16	4
A-114	Hex Nut	M20	1
A-115	Spacer		1
A-116	Belleville Spring Washer		2
A-117	Worm		1
A-118	Spacer		1
A-119	C-Clip	R-42	1
A-120	Ball Bearing	6004ZZ	1
A-121	Roll Pin		1
A-122	Key	6x95	1
A-123	Shaft	M6x8	1
A-124	Gear(L)		1
A-125	Intermediate Gear		1
A-126	Gear(S)		1
A-127	Ball Bearing	6202ZZ	1
A-128	Set Screw	M6x8	1
A-129	Bush		1
A-130	Rear Worm Gear		1
A-131	Key	6x20	1
A-132	Ball Bearing	6003ZZ	2
A-133	Hex Socket Cap Screw	M8x20	2
A-134	Rear Worm Gear Bracket		1
A-135	Hand Body		1
A-136	C-Clip	S-45	1
A-137	Ball Bearing	6009ZZ	2
A-138	Bearing Spacer		1
A-139	Spindle Sleeve	M12x80	1

NO.	Description	Size	Q'ty
A-140	Key	3x10	1
A-141	Drive Spindle Pulley	M=8,T=64	1
A-142	Rear Spindle Pulley	M=5,T=38	1
A-143	Pulley Guard		1
A-144	Safety Washer		1
A-145	Spring Washer	5/16"	2
A-146	Screw	5/16"x1/2"	2
A-164	Micro Switch Bracket		2
A-165	Micro Switch Support Rod		1
A-166	Micro Switch		2
A-167	Cross Head Screw	M3x16	2
A-168	Set Screw	1/4"x1/4"	2
A-176	Pin		1
A-177	Hand wheel Handle		1
A-178	Pin Hole Plate		1
A-179	Pointer		1
A-180	Handle wheel		1
A-181	Actuator Plate		1
A-182	Washer	M5	2
A-183	Screw	M5x10	2
A-184	Limit Switch		1
A-185	Cross Head Screw	M4x20	2
A-186	Feed Base		1
A-187	Depth Plate		1
A-188	Worm Shaft		1
G1	Pin	3x16	1
G2	Support Bracket Bar		1
G3	Bushing		1
G4	Spacer		1
G5	Lock Handle	M8x20	1
G6	C-Clip	S30	1
G7	Bracket		1
G8	Safety Guard		1
G9	Lower Bracket Bar		1
G10	Hex. Socket Cap Screw	M8x12	2
G11	Support Arm		1
G12	Hex. Nut	3/8"	2
G13	Spring Washer	3/8"	2
G14	Washer	5/16"	2
G15	Hex. Socket Cap Screw	M8x20	2
G16	Lock Bolt with Knob		1
G17	Spacer		1
G18	Switch		1
G19	Cross Cap Screw	M4x20	2

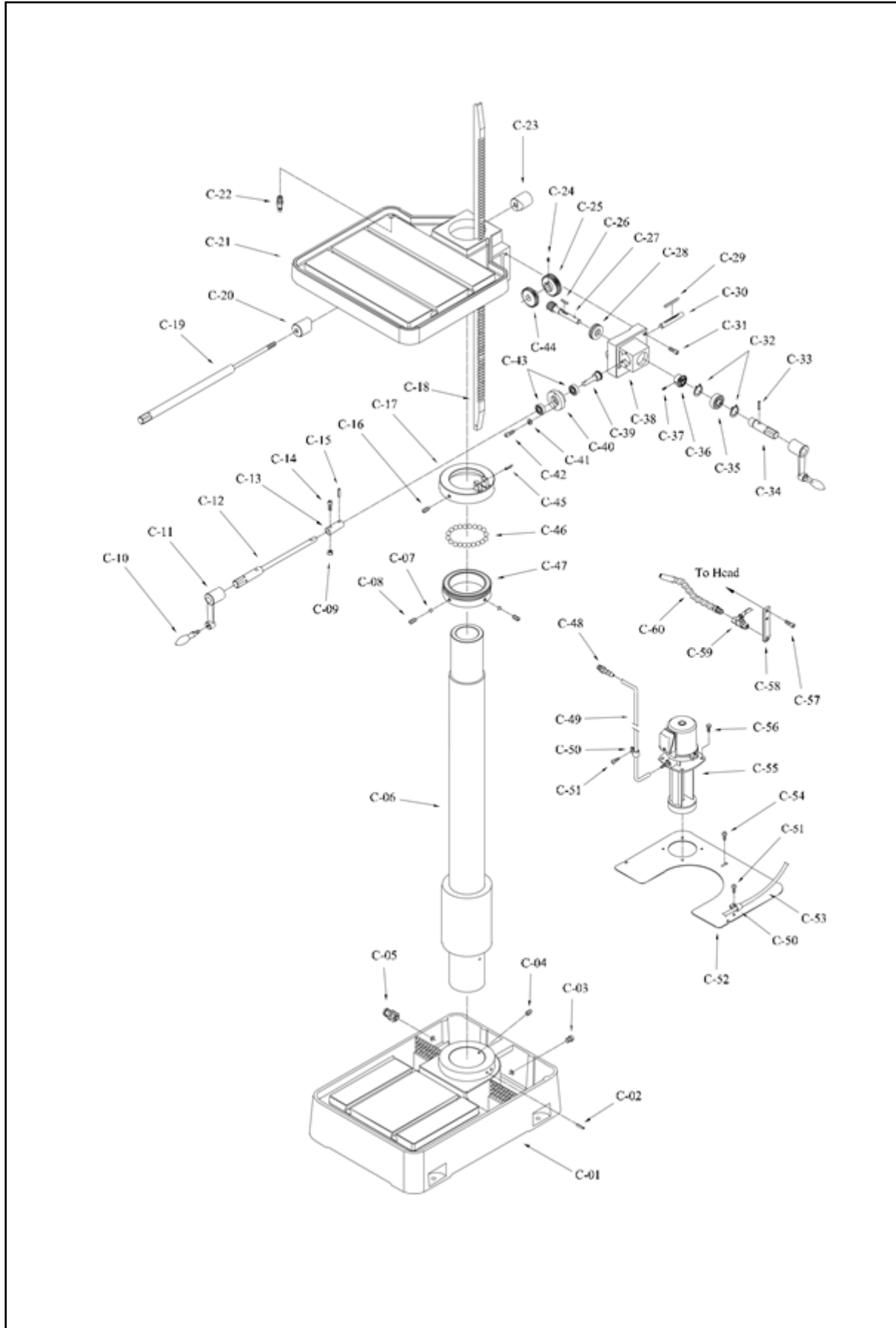

NO.	Description	Size	Q'ty
C-01	Coolant Base		1
C-02	Spring Pin	4x50	1
C-03	Hex Head Plugs	3/8"	1
C-04	Set Screw	1/2"x1"	2
C-05	Cable Relief		1
C-06	Column		1
C-07	Brass Block	3/8"	2
C-08	Set Screw	3/8"x5/16"	2
C-09	Hex Nut	1/4"	1
C-10	Handle		1
C-11	Lift Handle Crank		1
C-12	Crank Shaft Assembly		1
C-13	Sleeve		1
C-14	Hex Socket Cap Screw	1/4"x1-1/2"	1
C-15	Spring Pin	4x25	1
C-16	Set Screw	1/2"x3/4"	2
C-17	Column Bearing Collar		1
C-18	Rack		1
C-19	Connecting Rod (Thread)		1
C-20	Lock Sleeve		1
C-21	Table		1
C-22	Connector	3/8"	1
C-23	Lock Sleeve (Tread)		1
C-24	Set Screw	M6x6	1
C-25	Gear		1
C-26	Key	5x5x20	1
C-27	Worm Shaft		1
C-28	Thrust Bearing	51102	1
C-29	Key	5x5x80	1
C-30	Shaft		1
C-31	Hex Socket Cap Screw	M8x35	3
C-32	C-Clip	S-25	2

NO.	Description	Size	Q'ty
C-33	Spring Pin	4x25	1
C-34	Crank Shaft		1
C-35	Ball Bearing	6005Z	1
C-36	Bevel Gear		1
C-37	Set Screw	1/4"x3/8"	1
C-38	Gear Bracket		1
C-39	Small Bevel Gear		1
C-40	Flange		1
C-41	Spring Washer	M6	2
C-42	Hex Socket Cap Screw	M6x25	2
C-43	Ball Bearing	6206	2
C-44	Worm Gear		1
C-45	Spring Pin	4x50	1
C-46	Steel Ball	3/8"	40
C-47	Support Bearing Collar		1
C-48	Connector		1
C-49	Tube	1.5M	1
C-50	Clamping		2
C-51	Cross Cap Screw	3/16"x3/8"	2
C-52	Cover		1
C-53	Tube		1
C-54	Screw	1/4"x1/2"	3
C-55	Coolant Pump		1
C-56	Hex Cap Screw	1/4"x1/2"	4
C-57	Hex Socket Cap Screw	M8x20	2
C-58	Support Plate		1
C-59	ON/OFF Valve		1
C-60	Nozzle		1
C-61			
C-62			

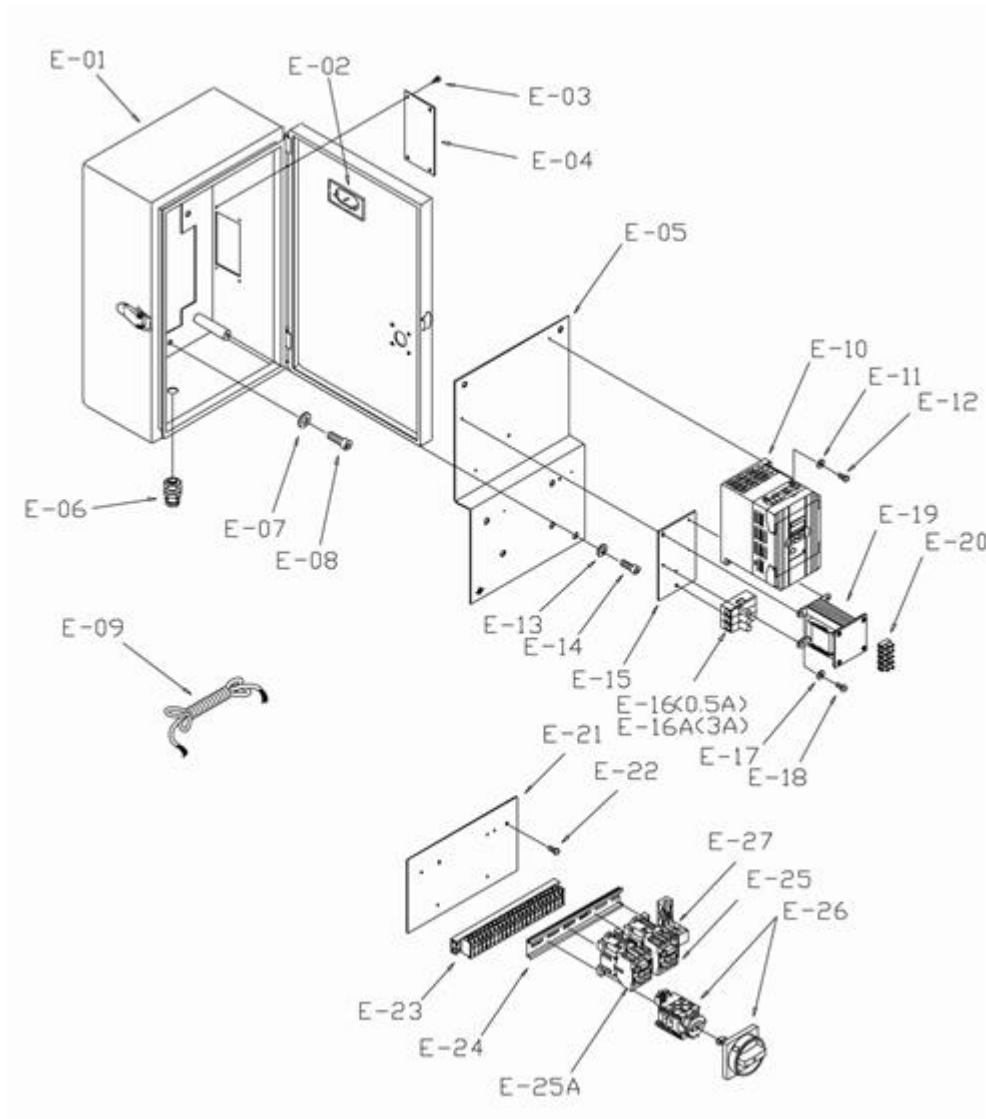

NO.	Description	Size	Q'ty
E-01	Electric Control Box w/Door and Latch		1
E-02	Plastic Plate		1
E-03	Screw	M4x6	4
E-04	Cover		1
E-05	Electric Base Plate		1
E-06	Cable Relief		1
E-07	Washer	M8	4
E-08	Hex Socket Cap Screw	M8x12	4
E-09	Electric Cable		1
E-10	Delta Inverter (for 480V)		1
E-11	Washer	M4	2
E-12	Screw	M4x20	2
E-13	Washer	M6	1
E-14	Hex Socket Cap Screw	M6x16	1
E-15	Insulation Board	140x78x3	1
E-16	Fuse (0.5A)		2
E-16A	Fuse (3A)		1
E-17	Washer	M4	4
E-18	Screw	M4x20	4
E-19	Transformer	400V / 24V	1
E-20	Terminal Plate		1
E-21	Connecting Board	230x130x3	1
E-22	Screw	M4x8	5
E-23	Terminal Plate	23P/600V/10A	1
E-24	Aluminum Rail Plate		1
E-25	Contactor	D12/24V/12A	1
E-25A	Contactor	D12/24V/12A	1
E-26	Safety Switch Assembly	3P 14A	1
E-27	Relay		1

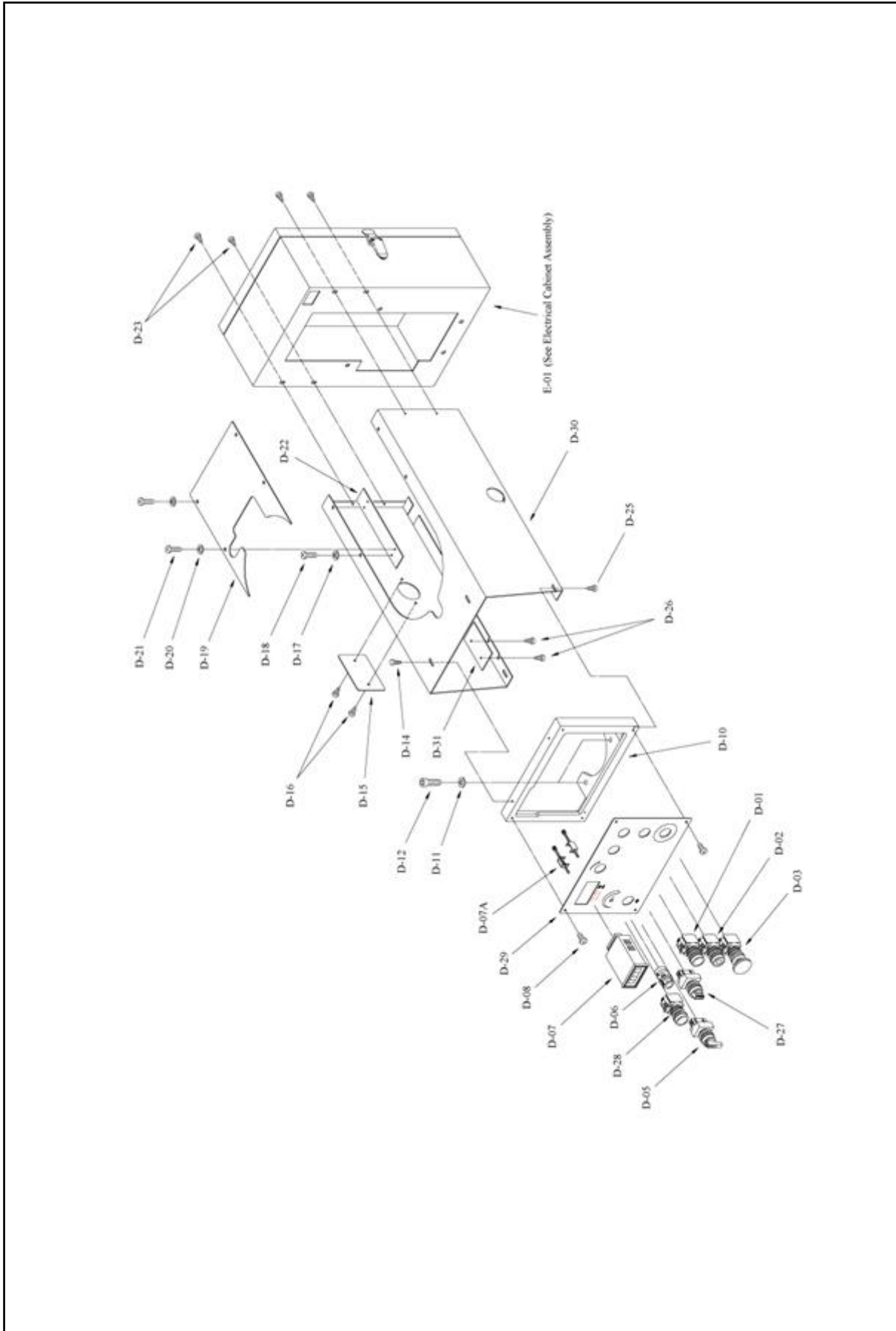

NO.	Description	Size	Q'ty
D-01	Start Switch		1
D-02	Stop Switch		1
D-03	Emergency Stop Switch		1
D-05	Pump Switch		1
D-06	Speed Control Knob		1
D-07	Speed Controller		1
D-07A	Holder Screw		2
D-08	Screw		4
D-10	Plate Bracket		1
D-11	Washer	M8	2
D-12	Hex Socket Cap Screw	M8x20	2
D-14	Screw	M5x8	2
D-15	Oil Filer Cover		1
D-16	Cross Head Screw	3/16"x3/8"	2
D-17	Washer	3/16"	4
D-18	Cross Head Screw	3/16"x3/8"	4
D-19	Top Cover		1
D-20	Washer	3/16"	4
D-21	Cross Head Screw	3/16"x3/8"	4
D-22	Fixed Plate		1
D-23	Cross Head Screw	M6x16	4
D-25	Screw	M5x8	2
D-26	Screw	M5x8	4
D-27	Tapping Switch		1
D-28	Reverse Switch		1
D-29	Control Panel L D		1
D-30	Pulley Cover		1
D-31	Dust Plate		2

Item designation	Description and function	Technical data	Quantity	Supplier	Suppliers reference	Remarks
Q	Disconnecting Device	Ui690V 16A IP54	1	KEDU	2H-C316	CE EN60947
FU1 FU2 FU3	Fuses	600V 0.5A 30mm 600V 3A	1 1 1	GIN SING		
KM1 KM2	Contactora	Coil 24V 50/60Hz Ui=660V AC1=25A AC3 220V 2.2KW 380V 4.0KW 4<<a>>	1 1	NHD	C-09D	CE ICE 158-1 BS 5424-1 VDE 0660 J13 8325
KR	Relay	2P	1	BETA	ZMY-2	UL
TC	Transformer	AC 380V 24V 52VA(1.2A)	1	Sam LI	2930N	CE
VFD-M	Variable speed AC Motor driver	380~460V 220~240V 2HP	1	DALTA	VFD-M	CE
BR	Braking resistors	200W,400Ω 200W,70Ω	1	DALTA		CE
VR	Adjust-speed switch		1	DALTA	RV-24YN20S B152	
SB3 SB2	Push buttons on Stop	600V PL 24V 1a 250V 10A 1b	1 1	MACK	BFL-22G BF-22R	
SB1	Emergency Stop	250V 4A 16	1	TONG CHUAG	LEPB-25R	CE
SB4	Tapping Switch	250V 3a	1	TONG CHUAN	PB-25G	IP-2
SB5 SB6	Reverse Switch Pump Switch	600V 250V 4A 1a 250V 4A 1a	1 1	TONG CHUAN	25 O.S.S.N L.S.S.N.	CE
XB	Terminal block	AC 600V 20V 1P 2X 10A	24		JTB 10	IP-2
QS1	Limit Switch	1	AC-15 3A / 240V	HIGHLY	ED-32	CE EN 60947-5-1 EN 50047 IP65
QS2 QS3	(Reverse) Micro-Switch (Forward)	1 1	AC 125V ,12A 250V , 6A	ZIPPY	VMVO6S 00600	UL VDE CSA
QS4	Limit Switch	1	250V 10A	TONG CHUAN	215 G1308	
M1	Motor	220V 2HP	1	KAI SHEN		ICE 34-1