

ONDERDEEL TEKENING

LZ315HA

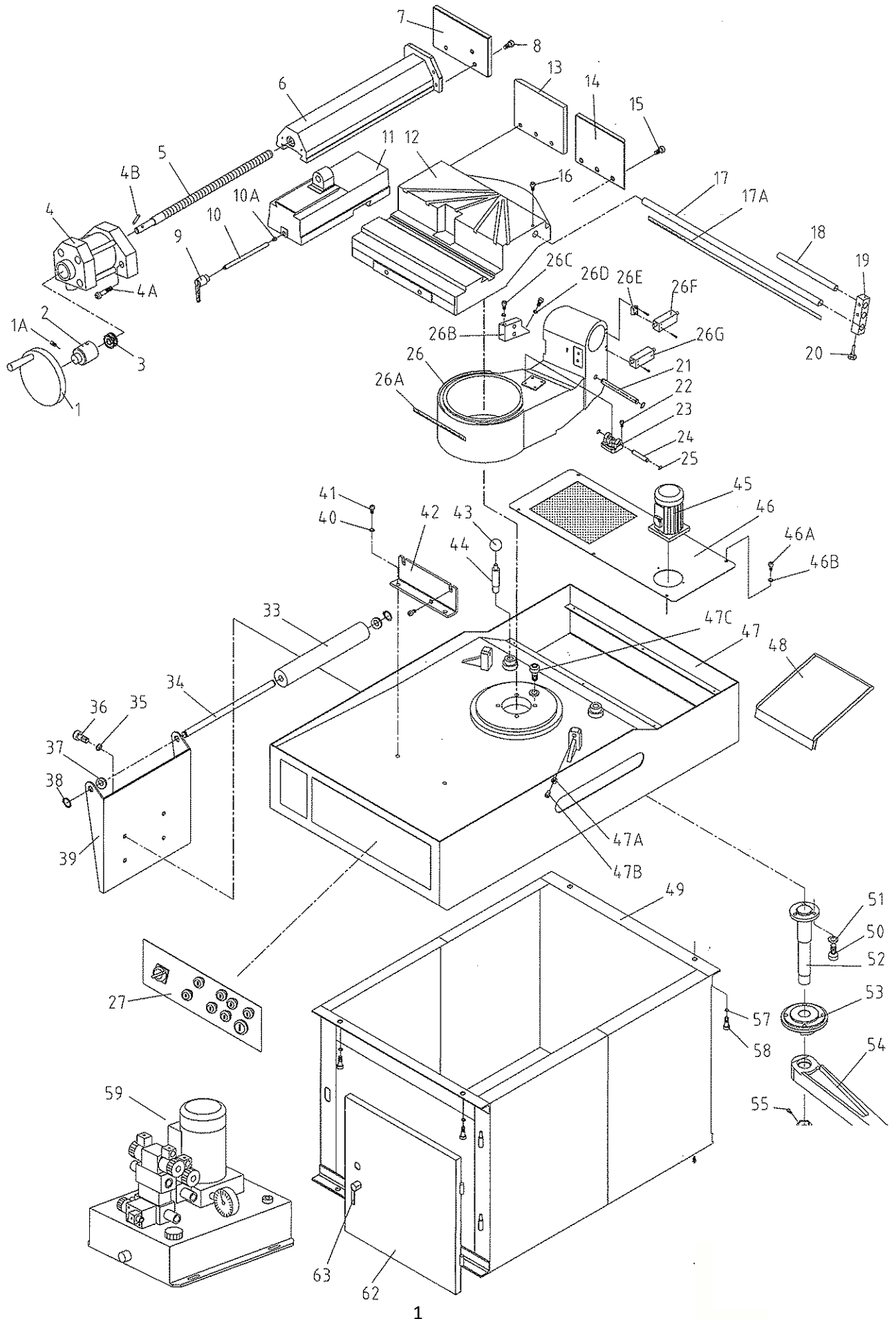

LZ315HA

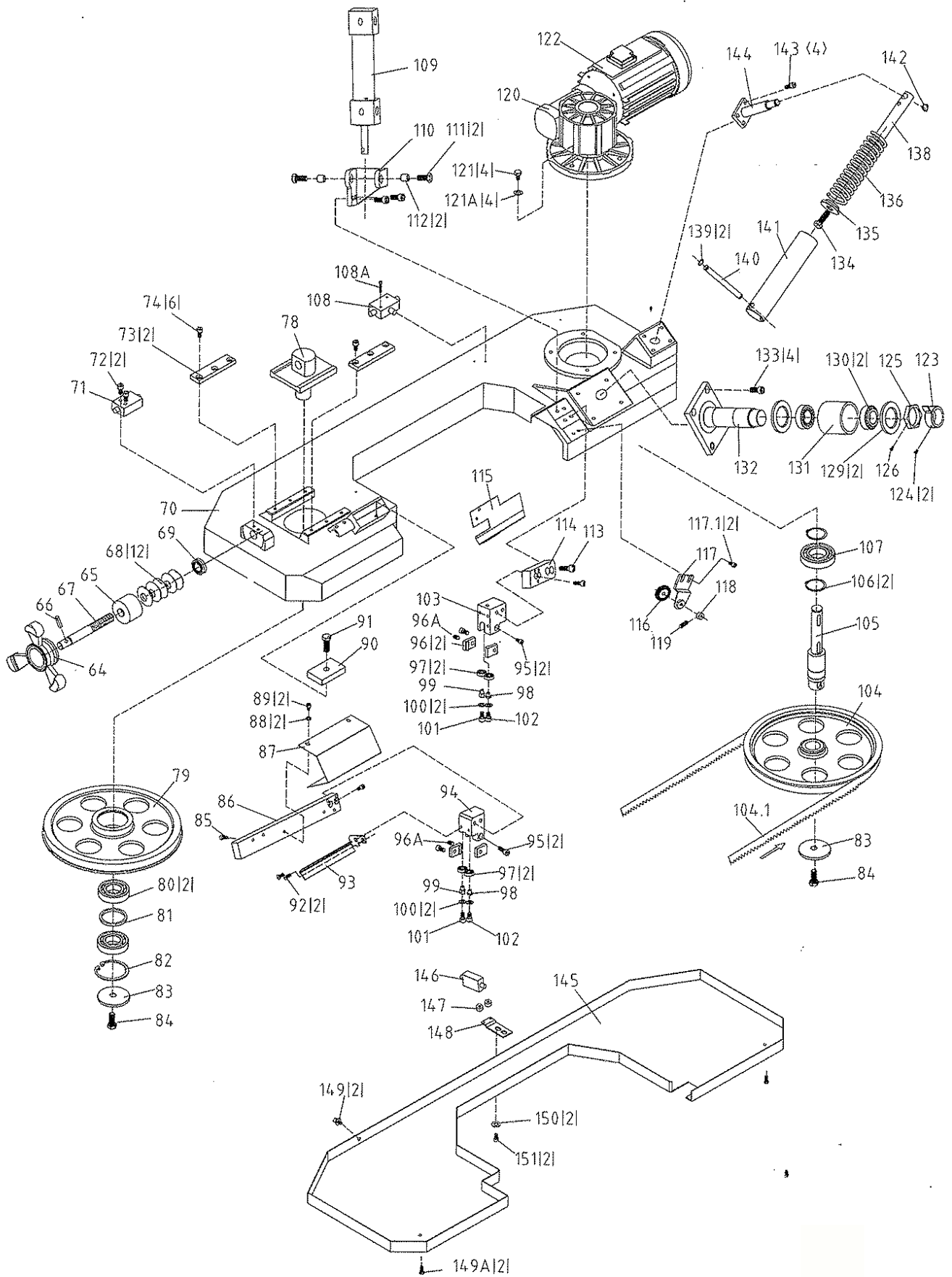

LZ315HA

Part #	Description	Q'ty	Part #	Description	Q'ty
1	Handle	1	33	Rollers	1
1A	Bolt		34	Shaft	1
2	Handlewheel shaft	1	35	Flat gasket	4
3	Bearing	1	36	Bolt	4
4	Clamping cylinder		37	Spacer bush	2
4A	Bolt	1	38	Check ring	2
4B	Spring pin	1	39	Stand	1
5	Screw rod	1	40	Flat gasket	4
6	Up vise	1	41	Nut	4
7	Sliding plate of vise	1	42	Stand	1
8	Bolt	3	43	Handle ball knob	2
9	Adjust handle	1	44	Shaft	1
10	Shaft	1	45	Cooling pump	1
10A	Prodsr	1	46	Cover plate	1
11	Connecting part of vise	1	46A	Bolt	6
12	Lower vise	1	46B	Flat gasket	6
13	Fixed plate of vise1	1	47	Chassis	1
14	Fixed plate of vise2	1	47A	Nut	2
15	Screw	6	47B	Bolt	2
16	Screw	1	47C	Bolt	4
17	Fixed link	1	48	Splash board	1
17A	Rulers	1	49	Leg	1
18	Keep-off Shaft	1	50	Bolt	3
19	Stop block	1	51	Flat gasket	3
20	Pentagon handle	1	52	Connect shaft	1
21	Shaft	1	53	Lock support	1
22	Screw	4	54	Lock handle	1
23	Cylinder fixed seat	1	55	Bolt	1
24	Cylinder Fixed Shaft	1	56	Nut	1
25	Ringshield	2	57	Flat gasket	4
26	Revolved Body	1	58	Bolt	4
26A	Scale	1	59	Hydraulic station	1
26B	limited block	1	62	Door	1
26C	Bolt	2	63	Door lock	1
26D	Nut	2	64	Handle	1
26E	Pad	1	65	Sleeve	1
26F	Up limit switch	1	66	Spring pin	1
26G	Lower limit switch	1	67	Adjuster bar	1
27	Operation panel	1	68	Disk spring	12

LZ315HA

Part #	Description	Q'ty	Part #	Description	Q'ty
69	Shaft	1	110	Stand for hydraulic cylinder	1
70	Saw bow	1	111	Bolt	2
71	Switch	1	112	Sleeve	2
72	Screw	2	113	Bolt	21
73	Platen	2	114	Connect plate	1
74	Bolt	6	115	Backplate	1
78	Siding seat	1	116	Brush	
79	Driven gear	1	117	Brush fixed mount	1
80	Shaft	2	117.1	Screw	2
81	spacer bush	1	118	Bushing	1
82	Check ring	1	119	Bolt	1
83	Pad	2	120	Gearbox	1
84	Bolt	2	121	Bolt	4
85	Screw	1	122	Motor	1
86	Adjust sand	1	123	Travel switch holder	1
87	Protect panel	1	124	Bolt	2
88	Flat washer	2	125	Nut	1
89	Nut	2	126	Screw	1
90	Press plate	1	129	Bearing cover	2
91	Bolt	1	130	Bearing	2
92	Nut	2	131	Spacer bush	1
93	Backplate	1	132	Revolving Shaft	1
94	Adjusting seat	1	133	Screw	4
95	Nut	2	134	Screw	1
96	Clamping block	4	135	Pressure pad	1
96A	Nut	2	136	Pressure spring	1
97	Shaft	4	138	Shaft	1
98	Eccentricity ring	2	139	Ringshield	2
99	Eccentricity ring	2	140	Shaft	1
100	Flat washer	4	141	Sleeve	1
101	Screw	2	142	Ringshield	1
102	Screw	2	143	Screw	4
103	Adjusting seat	1	144	Shaft seat	1
104	Driver gear	1	145	Bow shield	1
104.1	Blade	1	146	Bow shield switch	1
105	Shaft	1	147	Route switch pad	2
106	Check ring	2	148	Key switch plate	1
107	Shaft	1	149	Screw	2
108	Cooling block	1	149A	Screw	2
108A	Nut	4	150	Flat washer	2
109	Hydraulic cylinder	1	151	Screw	2