

REX N100A (Base)

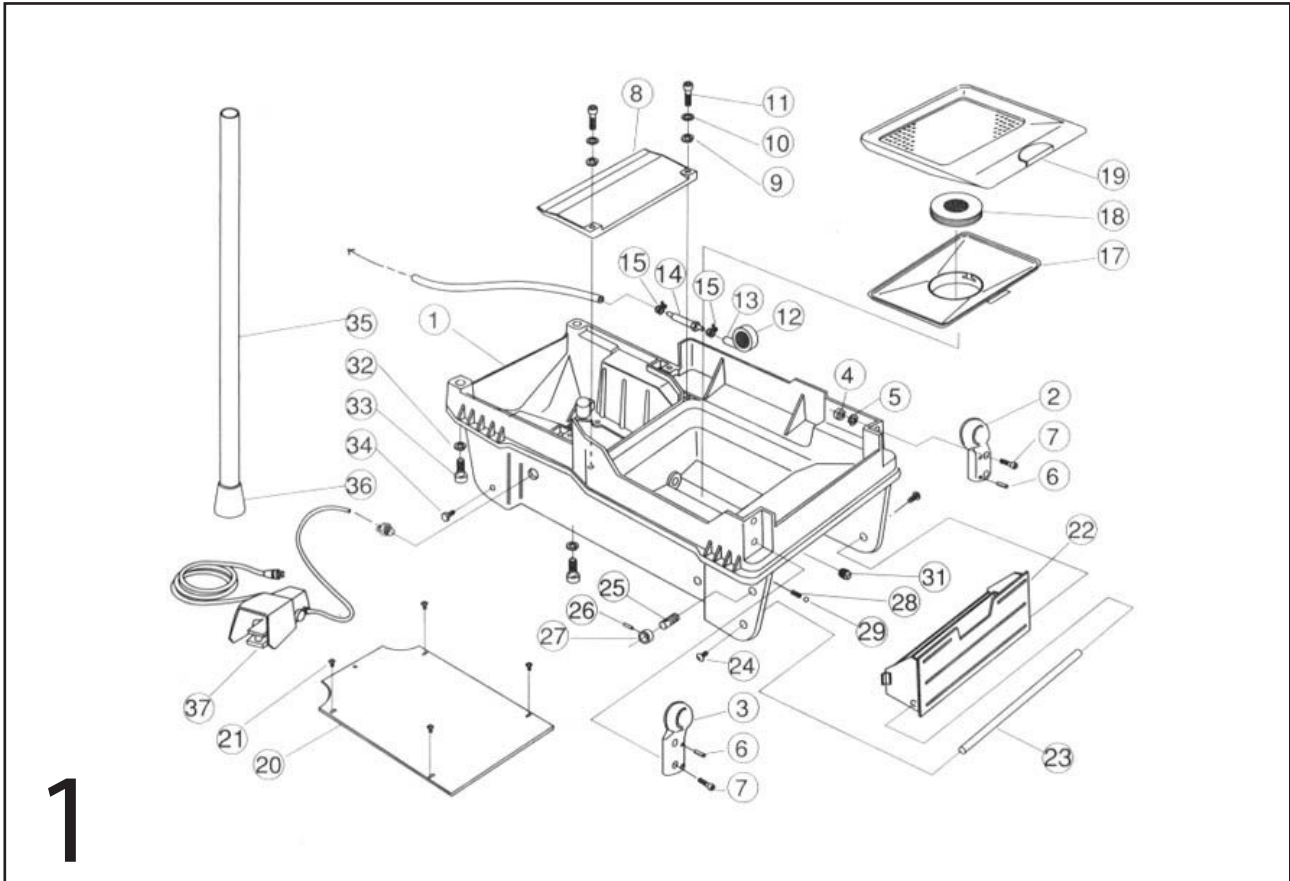

1

No.	Part No.	Part Name	Set	
1	J060	Base	1	
2	J002	Support (Right)	1	
3	J003	Support (Left)	1	
4		Nut (M8)	4	
5		Spring washer (φ8)	4	
6		Roll pin (φ6×30)	4	
7		Socket head cap screw (M8×25)	4	
8	J006	Base cover	1	
9		Washer (φ5)	2	
10		Spring washer (φ5)	2	
11		Round head machine screw (M5×25)	2	
12	N048	Strainer	1	Set Tapping screw (M5×10)
13		Oil intake line suction tube A	1	
14	J015	Nipple	1	
15		Pipe band	2	
16				
17	J004	Tank upper cover	1	
18	J005	Upper cover strainer cap	1	
19	J007	Scrap receiver	1	
20	J008	Bottom cover for CE	1	
21		Round head machine screw (M5×8)	4	
22	J010	Built-in tool box	1	
23	J011	Tool box shaft	1	
24		Truss screw (M8×20)	2	
25	J012	Stopper pin A	1	
26	J013	Stopper pin B	1	
27		Roll pin (φ4×20)	1	
28	7752	Spring (φ5×12)	1	
29		Steel ball (φ5)	1	
30				
31		Drain plug	1	
32		Spring washer (φ10)	4	
33		Socket head cap screw (M10×40)	4	
34		Hex-socket set screw (M10×30)	4	
35	N121	Pipe stand (790mm)	4	
36	N125	Leg cap	4	
37	FSW1	Foot switch	1	with Cord bush
38				
39				



REX N100A (Main shaft)

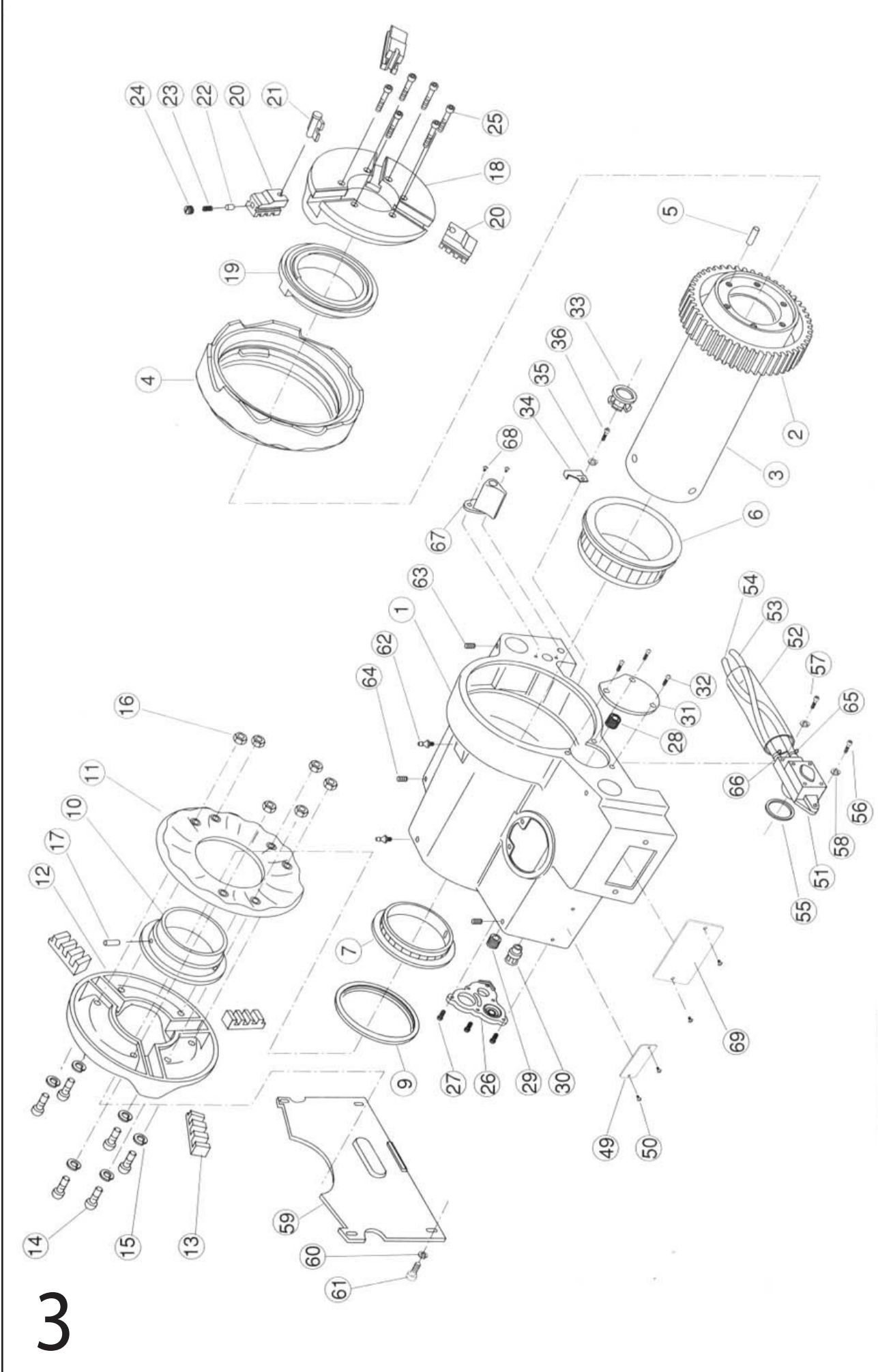

## REX N100A (Main shaft)

No.	Part No.	Part Name	Set	
1	J061	Head stock	1	
2	J036	Main shaft gear	1	} Set 02JJ
3	J038	Main shaft	1	
4	J703	Head wheel	1	
5		Straight pin (φ8×18)	1	
6	A005	Front main shaft bearing	1	
7	J039	Rear main shaft bearing	1	
8				
9	A008	Thrust ring	1	
10		Rear scroll	1	} Set J058 Rear chuck complete set (No.10~16)
11		Rear chuck cover	1	
12		Rear chuck receptacle	1	
13	A0SS	Rear chuck jaw	3	
14		Socket head cap screw (M6×16)	6	
15		Spring washer (φ8)	6	
16		Nut (M6)	6	
17		Roll pin (φ6×14)	3	
18	JH00	Chuck body	1	} Set J050 Chuck complete set (No.18~24) RS type } Chuck jaw insert set RS A0RS
19	JS00	Chuck scroll	1	
20		Chuck jaw set	3	
21		Chuck jaw insert set	3	
22		Spring retainer	3	
23		Spring	3	
24		Set screw	6	
25		Socket head cap screw (M7×57.5)	6	
26	J040	Gear case cover	1	
27		Socket head cap screw (M5×18)	6	
28		Hex-socket pipe plug (PT 1/8")	1	
29		Hex-socket pipe plug (PT 3/8")	1	
30	J320	Oil gauge (N-1)	1	
31	J042	Window cap	1	
32		Round head machine screw (M5×10)	3	
33	4040	Hose guide	1	
34	4086	Hose band	1	
35		Spring Washer (φ6)	1	
36		Round head machine screw (M6×10)	1	
49		Name plate for CE	1	
50		Rivet (#4×5)	2	
51	4025	Gear pump	1	
52		Vinyl tube (100mm)	1	
53		Oil intake line suction tube B (700mm)	1	
54		Oil feed line tube (530mm)	1	
55	J047	Gear pump gasket	1	
56		Socket head cap screw (M6×20)	1	
57		Socket head cap screw (M6×35)	1	
58		Spring washer (φ6)	2	
59	J041	Rear cover	1	
60		Washer (φ6)	4	
61		Round head machine screw (φ6×12)	4	
62		Grease nipple (M6)	2	
63		Hex-socket set screw (cone M8×25)	3	
64		Hex-socket set screw (half dog M8×25)	1	
65		Pipe band (10mm)	2	
66	1035	Joint	2	
67	J059	Security collar	1	
68		Round head machine screw (M5×16)	2	
69		Warning plate	1	
70				
71				
72				
73				
74				
75				
76				
77				

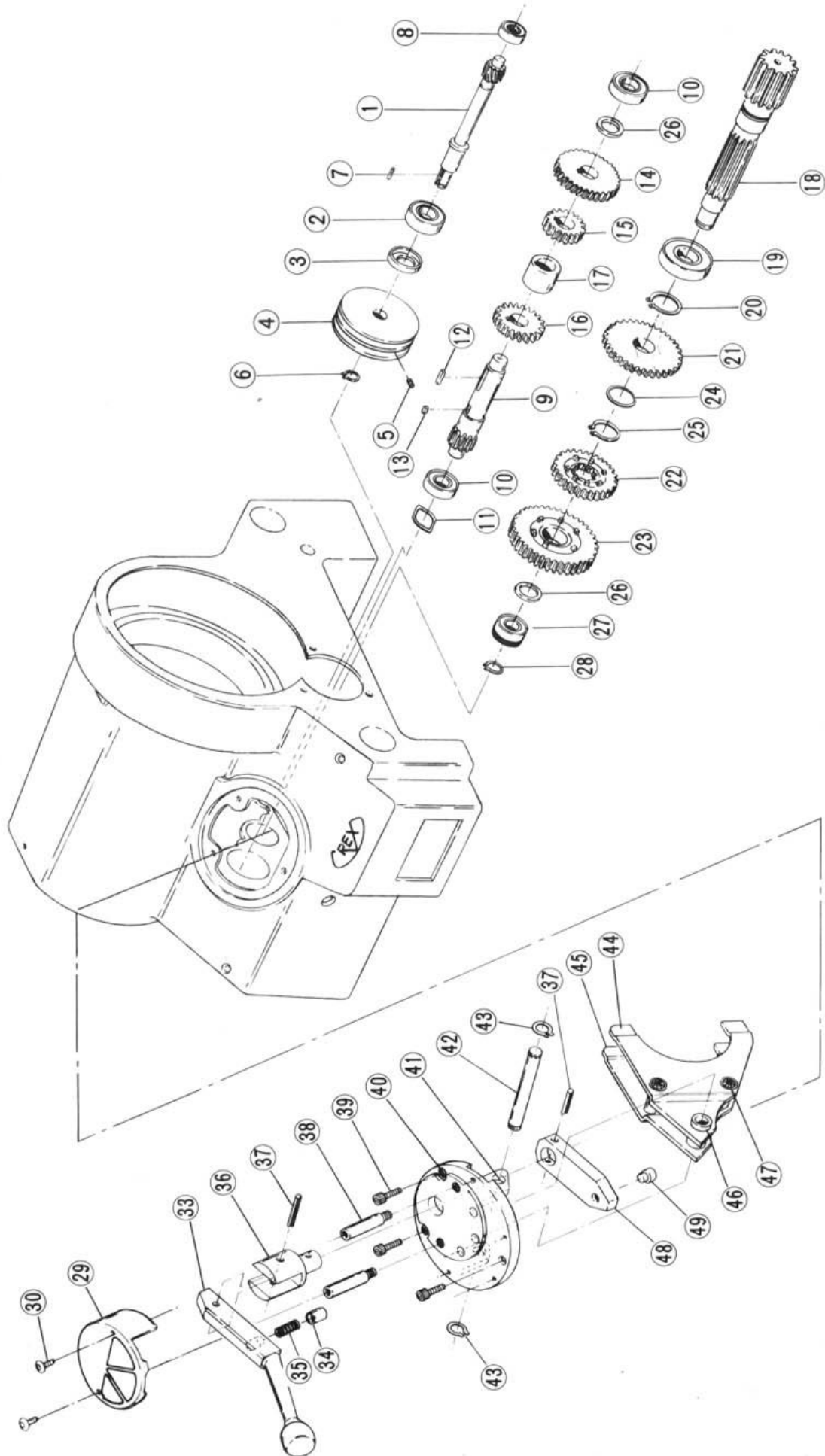



REX N100A (Gear case)

No.	Part No.	Part Name	Set	
1	J180	A shaft	1	
2	A192	Bearing (#6205LL)	1	
3	J310	Oil seal (TCV254511)	1	
4	4063	Mission Plley	1	For condenser motor (0.75kw 110/220V)
	4933	Mission Plley	1	For condenser motor (1.0kw 110/220V)
5	W78C	Hex-socket set screw (M8X14)	1	
6		Snap ring (out side φ18)	1	
7		Key (5X5X20)	1	
8	H272	Bearing (#6202LL)	1	
9	J81	B shaft	1	
10	A191	Bearing (#6204LL)	2	
11		Wave washer (BWW6203)	1	
12		Key (8X7X22)	1	
13		Key (8X7X12)	1	
14	J182	B shaft gear A	1	
15	J183	B shaft gear B	1	
16	J184	B shaft gear C	1	
17	J192	B shaft collar	1	
18	J185	C shaft	1	
19	J302	Bearing (#6007LLU)	1	
20		Snap ring (out side φ35)	1	
21	J186	C shaft gear A	1	
22	J187	C shaft gear B	1	
23	J188	C shaft gear C	1	
24	J194	C shaft collar (Small)	1	
25		Snap ring (out side φ30)	1	
26	J193	C shaft collar (Large)	2	
27	J301	Bearing (#6204ZNR)	1	
28		Snap ring (out side φ20)	1	
29	J201	Speed change cap	1	
30		Socket button head cap screw (M6X15)	2	
	OJHE1S	Speed change complete set		
32				
33	J202	Speed change lever	1	
34	J203	Notch pin	1	
35	J216	Spring	1	
36	J204	Speed change shaft	1	
37		Roll pin (φ6X30)	2	
38	J215	Stud bolt	2	
39		Socket head cap screw (M6X16)	3	
40	J200	Speed change cover	1	} Set J220
41	J206	Speed change guide	1	
42	J207	Guide pin	1	} Set J221
43		Snap ring (out side φ10)	2	
44	J209	Gear shift fork A	1	
45	J210	Gear shift fork B	1	
46	J211	Shift pin A	1	
47	J212	Shift pin B	2	
48	J205	Fork lever	1	
49	J208	Fork lever pin	1	
50				
51				
52				
53				
54				
55				
56				
57				
58				
59				
60				
61				
62				
63				
64				

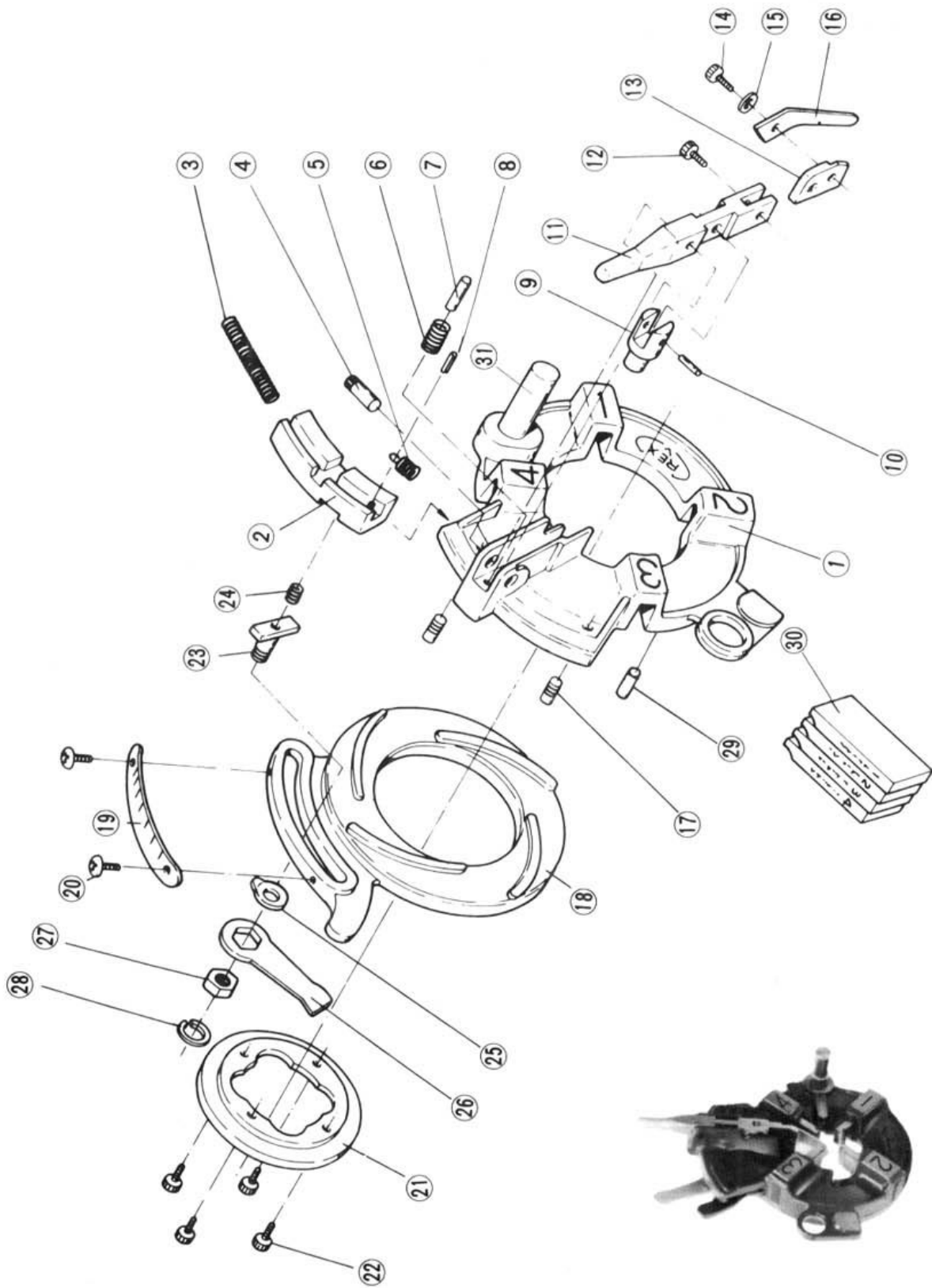









REX N100A (Carriage)

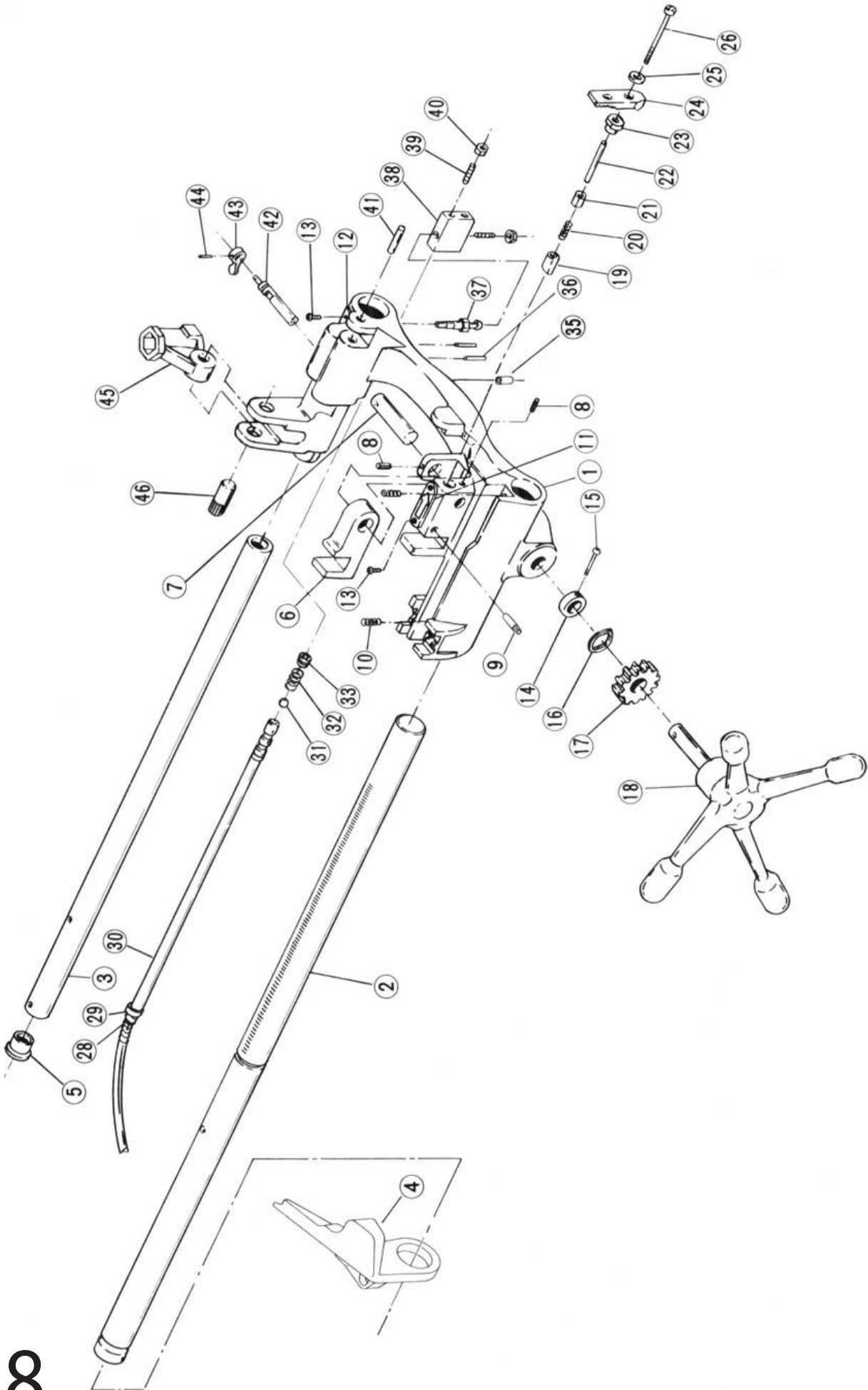

## REX N100A (Carriage)

No.	Part No.	Part Name	Set	
1	J110	Carriage	1	
2	J111	Carriage support bar A	1	
3	J112	Carriage support bar B	1	
4	J702	Safety collar	1	
5	J148	Carriage support bar B cap	1	
6	J113	Die head holder	1	
7	J114	Die head holder shaft	1	
8		Roll pin (φ5×12)	1	
9	1036	Oil joint pin	1	
10	E140	Spring	2	
11	J145	Open plate	1	
12	J155	Oil flow selector plate	1	
13		Rivet (#4×5)	4	
14	9018	Feed gear stop ring	1	
15		Round head machine screw (M5×30)	1	
16		Wave washer (φ20)	1	
17	A515	Carriage feed gear	1	
18	A517	Carriage handle (with feed gear shaft)	1	
19	A109	Die head stop pin	1	
20	A115	Spring	1	
21	J147	Knob pin bush S	1	
22	J139	Knob pin bush	1	
23	A110	Die head stop pin cover	1	
24	J136	Die head lock knob	1	
25	J137	Hemi-spherical washer	1	
26		Socket head cap screw (M5×60)	1	
27				
28		Copper wire (φ0.8×200mm)	1	
29	1035	Oil joint	1	
30	J140	Oil pipe (Large)	1	
31		Steel ball (φ8)	1	
32		Spring	1	
33		Hex-socket set screw (M10×10)	1	
34				
35		Notch (φ10)	1	
36		Roll pin (φ5×45)	2	
37	J142	Oil pipe (small)	1	
38	J141	Oil pipe connector	1	
39		Hex-socket set screw (cone M6×25)	2	
40		Jam nut (M6)	2	
41	1096	Reamer arm stop pin	1	
42	J143	Oil flow selector shaft	1	Set O-ring (φ12)
43	J144	Oil flow selector lever	1	
44		Roll pin (φ3×18)	1	
45	J162	Cutter arm	1	
46	J166	Cutter arm stop pin	1	
47				
48				
49				
50				
51				
52				
53				
54				
55				
56				
57				
58				
59				
60				
61				
62				
63				
64				
65				



